

# CROCK·POT®

◆ THE ORIGINAL SLOW COOKER ◆

**Smart-Set™**



**Cookbook and Owner's Manual**

Read and Keep These Instructions

[www.crock-pot.ca](http://www.crock-pot.ca)

# Table of Contents

<b>Important Safeguards</b> .....	E2
<b>Introduction</b> .....	E4
<b>Know Your Smart-Set™ Slow Cooker</b> .....	E5
<b>Before You Use Your Smart-Set™ Slow Cooker</b> .....	E5
<b>Assembly</b> .....	E5
<b>How to Use Your Smart-Set™ Slow Cooker</b> .....	E6
Auto Cook Mode .....	E7
Digital Timer Mode .....	E9
Dual Cycle Mode with Digital Timer .....	E10
Manual Mode.....	E11
Usage Notes.....	E12
<b>Care and Cleaning</b> .....	E13
<b>Cooking Hints and Tips</b> .....	E14
<b>Recipes</b> .....	E18
Brunch and Beverages.....	E21
Appetizers and Side Dishes.....	E26
Main Courses.....	E34
Poultry.....	E34
Pork and Sausage.....	E45
Beef.....	E54
Vegetarian.....	E63
Soups and Chowders.....	E66
Holidays and Special Occasions.....	E72
Desserts .....	E82
<b>Service Instructions</b> .....	E88
<b>Warranty</b> .....	E88

# *IMPORTANT SAFEGUARDS*

When using electrical appliances, basic safety precautions should always be followed, including the following:

1. Read all instructions before using.
2. Do not touch hot surfaces. Use handles or knobs.
3. To protect against electrical shock, do not immerse cord, plug, temperature probe cord, or heating base in water or other liquid.
4. Close supervision is necessary when any appliance is used by or near children.
5. Unplug from outlet when not in use and before cleaning. Allow unit to cool before putting on or taking off parts.
6. Do not operate any appliance with a damaged cord or plug or after the appliance malfunctions or has been damaged in any manner. Return appliance to the manufacturer (see warranty) for examination, repair, or adjustment.
7. The use of accessory attachments not recommended by the manufacturer may cause fire, electrical shock, or injury.
8. Do not use outdoors.
9. Do not let cord hang over edge of table or counter, or touch heated surfaces.
10. Do not place on or near a hot gas or electric burner, or in a heated oven.
11. Extreme caution must be used when moving an appliance containing hot oil or other hot liquids. Always use hot pads when moving your heated slow cooker.
12. Do not use appliance for other than intended use.
13. Avoid sudden temperature changes, such as adding refrigerated foods into a heated pot.
14. To disconnect, press the OFF button then remove plug from wall outlet.
15. Keep 6 inches clear from the wall and 6 inches clear on all sides.
16. **CAUTION:** To prevent damage or shock hazard, do not cook on heating base. Cook only in the stoneware provided.

## *SAVE THESE INSTRUCTIONS*

This appliance is for HOUSEHOLD USE ONLY.

No user-serviceable parts inside. Do not attempt to service this product.

A short power-supply cord is provided to reduce the hazards resulting from entanglement or tripping over a longer cord. AN EXTENSION CORD MAY BE USED WITH CARE; HOWEVER, THE MARKED ELECTRICAL RATING SHOULD BE AT LEAST AS GREAT AS THE ELECTRICAL RATING OF THE SLOW COOKER. The extension cord should not be allowed to drape over the counter or tabletop where it can be pulled on by children or tripped over unintentionally.



### POLARIZED PLUG

This appliance has a polarized plug, (one blade is wider than the other). As a safety feature to reduce the risk of electrical shock, this plug is intended to fit in a polarized outlet only one way. If the plug does not fit fully in the outlet, reverse the plug. If it still does not fit, contact a qualified electrician. Do not attempt to defeat this safety feature or modify the plug in any way. If the plug fits loosely into the AC outlet or if the AC outlet feels warm do not use that outlet.

**IMPORTANT NOTE:** Some countertop and table surfaces, such as Corian® and other surfaces, are not designed to withstand the prolonged heat generated by certain appliances. We recommend placing a hot pad or trivet under your slow cooker to prevent possible damage to the surface.

**NOTE:** During initial use of this appliance, some slight smoke and/or odor may be detected. This is normal with many heating appliances and will not recur after a few uses.

**NOTE:** Please use caution when placing your stoneware on a ceramic or smooth glass cook top stove, countertop, table, or other surface. Due to the nature of the stoneware, the rough bottom surface may scratch some surfaces if caution is not used. Always place protective padding under stoneware before setting on table or countertop.

## *Introduction*

Just when you thought slow cooking couldn't get any easier, the Smart-Set™ slow cooker takes it to a whole new level: Advanced cooking capabilities at the touch of a button help you customize your cooking to create a gourmet meal. What's more, it works around your schedule.

By taking out all of the guesswork, the Smart-Set™ slow cooker allows you to cook any type of meat to perfection. The pre-set meat options and digital thermometer ensure optimal flavor, and the slow cooker automatically switches to the WARM setting when the food is done, so your meal is always delicious and table-ready despite your busy schedule. The Smart-Set™ slow cooker also follows any recipe without constant supervision, even if the recipe calls for a change in temperature a few hours into cooking. Finally, you can spend your time enjoying a home-cooked meal rather than preparing it.

Your family and guests will certainly be impressed not only by the premium taste of the culinary creations you and your Smart-Set™ slow cooker cook up, but also by the unique functional and aesthetic qualities of the slow cooker. With a six-quart capacity, convenient hinged lid for serving, and WARM setting, the Smart-Set™ slow cooker will be the staple of family dinners and the envy of the buffet table. Whether you are a home chef who demands precision cooking or an amateur with a history of under - or over-cooking food, the Smart-Set™ slow cooker will soon play an indispensable role in your meal preparation.

It will only take one meal to understand why the Smart-Set™ slow cooker is the chef's favorite!

## Know Your Smart-Set™ Slow Cooker

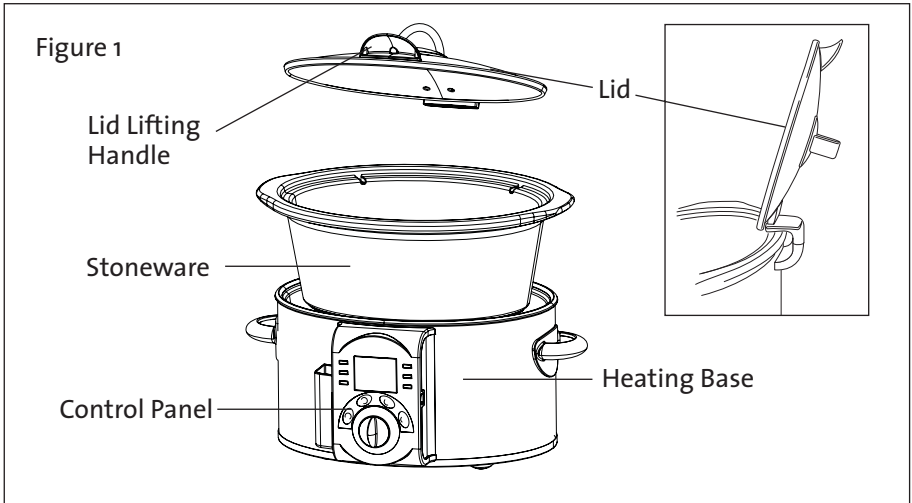

## Before You Use Your Smart-Set™ Slow Cooker

Before you use your slow cooker, wash the lid, stoneware, temperature probe, and temperature probe housing in warm, soapy water and dry thoroughly. NEVER immerse the heating base in water or any other liquid.

## Assembly

1. Place Stoneware into the Heating Base.
2. Lower the Lid horizontally down onto the Stoneware. Be sure to align the Lid Hinge so that it slides down onto the mating Heating Base Hinge. (See Figure 2)
3. When raising and lowering the Lid, use the Lid Lifting Handle. (See Figure 1)

Caution: When disassembling, ALWAYS remove the lid first, and then remove the stoneware.

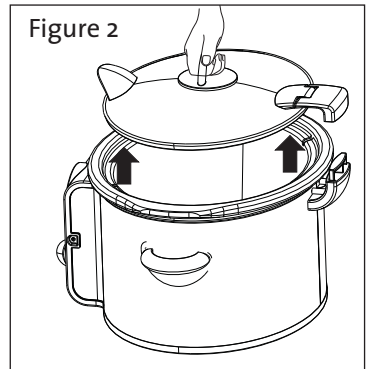

# How to Use Your Smart-Set™ Slow Cooker

Figure 3

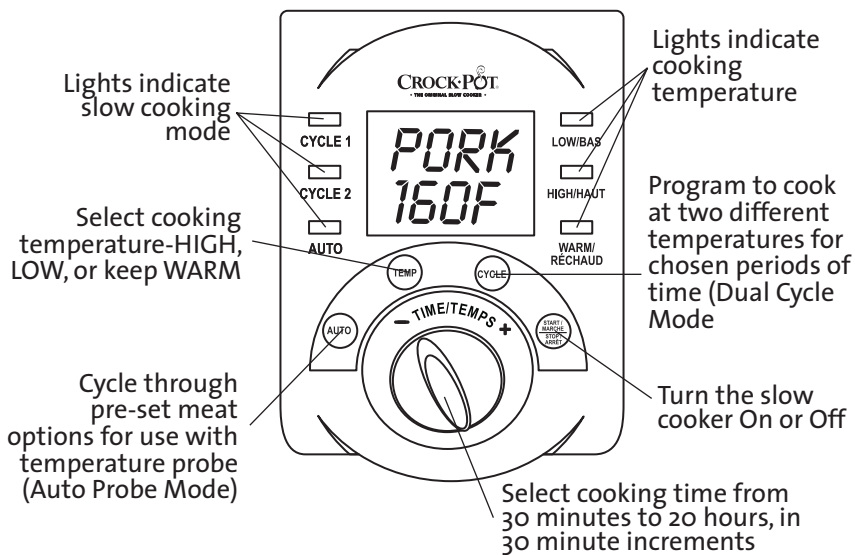
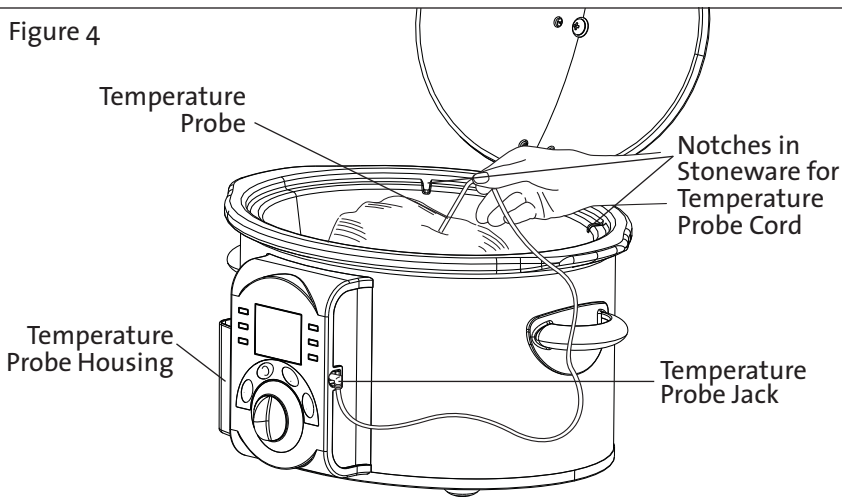

Figure 4



## Auto Cook Mode

*The Auto Cook Mode cooks your meal based on both temperature and time settings; your meal is done when it has reached the safe internal temperature and then has simmered to reach the optimal taste. The pre-set meat options and digital thermometer ensure perfect results, regardless of the size or cut of your meat, and the Smart-Set™ slow cooker automatically switches to the WARM setting so that your meal is always warm and ready to serve. Use this mode when taste is your top concern, as it was designed to produce optimal results every time.*

1. Place the stoneware into the heating base.
2. Prepare your ingredients and place them into the stoneware.
3. Plug the temperature probe cord into the temperature probe jack on the heating base. (See Figure 4)
4. Insert the temperature probe into the thickest piece of meat or center of dish. Attach the lid to the heating base, allowing the temperature probe cord to set in the notch of the stoneware, under the closed lid. (See Figure 4)  
NOTE: If the temperature probe cord is pulled out of the temperature probe jack while the unit is plugged into an electrical outlet, the slow cooker will beep and display PROB OUT until the temperature probe cord is plugged back into the temperature probe jack.
5. Plug the heating base into a standard outlet.
6. Press the AUTO button to cycle through and select BEEF, POUL (poultry), PRK1 (bone-in pork), PRK2 (boneless pork), CHIL (chili), or STEW.
7. Press the TEMP button to select HIGH or LOW.
8. Press the START/STOP button to start cooking. The upper display shows the AUTO selection, the lower display shows the internal temperature of the food, and the corresponding temperature light illuminates. The lower display will reflect the internal temperature, as it changes.
9. When the internal temperature of the meat reaches the safe temperature, the slow cooker beeps once, the upper display shows "SIMR," and the lower display shows the additional cook time\* (see chart on page 17) and then starts to count down. At this point, the food is simmering until it reaches its optimal taste.
10. When the cook time expires, the slow cooker beeps twice, and the temperature shifts to WARM. The upper display shows WARM and the lower display is off.



## **Auto Cook Mode (cont.)**

11. To change any settings after you have already pressed the START/STOP button, you must make your new selections and press the START/STOP button so that the slow cooker recognizes the new settings.
12. Press the START/STOP button to turn off the slow cooker, then unplug it from the outlet.

### **Important Information about the Temperature Probe**

- Clean the temperature probe and the temperature probe housing with hot, soapy water before and after each use.
- Place the temperature probe into the thickest part of the meat, roast, or food before you program in the Auto Probe Mode cooking cycle.
- Insert the temperature probe into the thickest part of the food so that it is not touching any bone or fat.
- Leave the temperature probe in the food throughout the cooking cycle.
- Be careful when removing the temperature probe from the food; the temperature probe is HOT!

## Digital Timer Mode

*The Digital Timer Mode allows you to set a time and temperature at which your meal will cook, anytime from 30 minutes to 20 hours (in half-hour increments), and follow along as the digital display counts down the remaining cook time. When it's done cooking, the Smart-Set™ slow cooker automatically switches to the WARM setting so that your meal stays warm until you're ready to serve it. The Digital Timer Mode is great for easy meal planning, as it requires no supervision and tells you exactly when your meal will be ready. It is ideal for recipes that call for one constant temperature throughout the entire cook time.*

1. Place the stoneware into the heating base.
2. Prepare your ingredients and place them into the stoneware.
3. Attach the lid to the heating base, and plug the heating base into a standard outlet.
4. Press the TEMP button to select LOW or HIGH. The temperature light that you select flashes. Refer to the “Converting Your Recipes” section for information on temperature settings.
5. Turn the SET TIME dial to select the amount of time you want to cook at the selected temperature. The temperature light illuminates and the time flashes in the upper display.
6. Press the START/STOP button to start cooking. The amount of time that you dialed shows in the upper display and starts counting down and the corresponding temperature light remains illuminated. When the selected time expires, the slow cooker beeps twice and switches to the WARM setting. WARM shows in the upper display, the WARM light illuminates, and the temperature light goes off.
7. Press the START/STOP button to turn off the slow cooker, then unplug it from the outlet.

## Dual-Cycle Mode with Digital Timer

*The Dual-Cycle Mode operates the same way as the Digital Timer Mode, but it takes things one step further! This mode allows you to set your slow cooker to cook at one temperature for a specified time and then automatically switches over to another temperature for additional time before switching to the WARM setting. You can customize recipes without being present, giving you greater control over the cooking process.*

1. Place the stoneware into the heating base.
2. Prepare your ingredients and place them into the stoneware.
3. Attach the lid to the heating base, and plug the heating base into a standard outlet.
4. Press the TEMP button to select LOW or HIGH. The temperature light that you select flashes. Refer to the “Converting Your Recipes” section for information on temperature settings.
5. Turn the SET TIME dial to select the amount of time you want to cook at the selected temperature. The time flashes in the upper display and the temperature light illuminates.
6. Press the CYCLE button and the time in the upper display stops flashing and dims and the other temperature light flashes.
7. Turn the SET TIME dial to select the amount of time you want to cook at the 2<sup>nd</sup> temperature. The time flashes in the lower display and the 2<sup>nd</sup> temperature light illuminates.
8. Press the START/STOP button to start cooking. The time in the lower display stops flashing and dims, the first temperature light illuminates, the upper display brightens and starts to countdown, and the second temperature light goes off. When slow cooker has run for the selected time on CYCLE 1, the slow cooker beeps once and switches to the CYCLE 2 program for the selected time. Once CYCLE 2 has run for the selected time, the slow cooker beeps twice and switches to the WARM setting. The slow cooker remains on WARM until you turn the slow cooker off.
9. To change any settings after you have already pressed the START/STOP button, you must make your new selections and press the START/STOP button so that the slow cooker recognizes the new settings.
10. Press the START/STOP button to turn off the slow cooker, then unplug it from the outlet.

## Manual Mode

*Using the Manual Mode, you simply set a temperature and the slow cooker cooks at that temperature until you either switch it to another temperature or turn it off. You may want to use this mode if you are unsure of how long you want to cook your meal, or if you have some extra time to linger about the kitchen and want to more closely supervise the cooking.*

1. Place the stoneware into the heating base.
2. Prepare your ingredients and place them into the stoneware.
3. Attach the lid to the stoneware, and plug the heating base into a standard outlet.
4. Press the TEMP button to select LOW or HIGH. The temperature that you select flashes in the upper display. Refer to the “Converting Your Recipes” section for information on temperature settings.  
WARM is ONLY for keeping hot, already cooked food at the perfect serving temperature until you are ready to eat. DO NOT cook on the WARM setting.
5. Press the START/STOP button to start cooking. The cooking temperature that you selected shows in the upper display and the corresponding temperature light illuminates.
6. To change any settings after you have already pressed the START/STOP button, you must make your new selections and press the START/STOP button so that the slow cooker recognizes the new settings.
7. Press the START/STOP button to turn off the slow cooker, then unplug it from the outlet.

## Usage Notes

- If there is a power outage, when the power is restored the display and lights blink. All slow cooker settings have been cleared and must be reset. However, the food may be unsafe to eat. If you are unaware of how long the power was out, we suggest you discard the food.
- For recipes that require a range of times, select the time closest to the setting on your slow cooker. For instance, to cook a recipe calling for a cooking time of 7 to 9 hours on LOW, set your slow cooker to 8 hours.
- To avoid over- or under-cooking, always fill the stoneware  $\frac{1}{2}$  to  $\frac{3}{4}$  full to conform to recommended cook times (with the exception of certain cakes and custards, and as guided otherwise in our slow cooker recipes). Do not overfill the stoneware.
- Always cook with the lid on for the recommended time. Do not remove the lid during the first two hours of cooking.
- Always wear oven mitts when handling the lid.
- Unplug when cooking is done and before cleaning.
- Do not store foods in the slow cooker stoneware.
- Do not reheat foods in your slow cooker.
- Removable stoneware is ovenproof and microwave safe. Do not use removable stoneware on gas or electric burner or under broiler. Refer to chart below.

PART	DISHWASHER SAFE	OVEN SAFE	MICROWAVE SAFE	STOVETOP SAFE
Heating Base	No	No	No	No
Stoneware	Yes	Yes	Yes	No
Lid	Yes	No	No	No
Temperature Probe	No	No	No	No
Temperature Probe Housing	Yes	No	No	No

## CARE AND CLEANING

### Stoneware and Lid

- ALWAYS turn your slow cooker off, unplug it from the electrical outlet, and allow it to cool before cleaning.
- The removable stoneware and lid go safely into the dishwasher, or may be washed in hot, soapy water. Do not use abrasive cleaning compounds; a cloth, a sponge, or rubber spatula will usually remove the residue. To remove water spots and other stains, use a non-abrasive cleaner or vinegar.
- Use hot water to wash your stoneware right after cooking. Do not add cold water if the stoneware is hot. As with any fine ceramic, the stoneware will not withstand sudden temperature changes and could crack.
- If the stoneware has been preheated or is hot to the touch, do not add cold foods. Do not preheat your slow cooker unless specified in the recipe. The stoneware should be at room temperature when adding hot or cold foods.

### Heating Base

- The outside of the heating base may be cleaned with a soft cloth and warm soapy water. Wipe dry. Do not use abrasive cleaners.  
CAUTION: Never immerse the heating base in water or other liquid.

### Temperature Probe and Housing

- The temperature probe can be washed in warm, soapy water and wiped dry.
- The temperature probe housing is removable for cleaning. Simply slide housing up to remove.
- The housing is dishwasher safe (top rack only), or can be washed in warm, soapy water and wiped dry.

## *Cooking Hints and Tips*

### **Pasta and Rice**

- If you are converting a recipe that calls for uncooked noodles, macaroni, or pasta, cook them on the stovetop just until slightly tender before adding to slow cooker.
- If you are converting a recipe that calls for cooked rice, stir in raw rice with other ingredients; add  $\frac{1}{4}$  cup extra liquid per  $\frac{1}{4}$  cup of raw rice. Use long grain converted rice for best results in all-day cooking.

### **Beans**

- Beans must be softened completely before combining with sugar and/or acidic foods. Sugar and acid have a hardening effect on beans and will prevent softening.
- Dried beans, especially red kidney beans, should be boiled before adding to a recipe. Cover the beans with three times their volume of unsalted water and bring to a boil. Boil 10 minutes, reduce heat, cover and allow to simmer  $1\frac{1}{2}$  hours or until beans are tender. Soaking in water, if desired, should be completed before boiling. Discard water after soaking or boiling.
- Fully cooked canned beans may be used as a substitute for dried beans.

### **Vegetables**

- Many vegetables benefit from slow cook times and low temperatures and are able to develop their full flavor. They tend not to overcook in your slow cooker as they might in your oven or on your stovetop.
- When cooking recipes with vegetables and meat, place the vegetables in the stoneware before the meat. Vegetables usually cook slower than meat in the slow cooker.
- Place vegetables near the sides or bottom of the stoneware to facilitate cooking. Stir in chopped or sliced vegetables with other ingredients.
- Because eggplant has a very strong flavor, you should parboil or sauté the eggplant before adding it to the slow cooker.

## Liquids

- It is not necessary to use more than  $\frac{1}{2}$  to 1 cup liquid in most instances since juices in meats and vegetables are retained more in slow cooking than in conventional cooking. When converting conventional cooking recipes to slow cooking recipes, use about half of the recommended amount of liquids, except in recipes that contain uncooked rice or pasta (see previous page).

## Milk

- Milk, cream, and sour cream break down during extended cooking. When possible, add during last fifteen minutes to half hour of cooking, until just heated through.
- Condensed soups may be substituted for milk and can cook for extended times.

## Soups

- Some soup recipes call for 2 to 3 quarts of water. Add other soup ingredients to the slow cooker first; then add water only to cover. If thinner soup is desired, add more liquid at serving time.
- If milk-based soup recipes have no other liquid for initial cooking, add 1 or 2 cups water. Since milk, cream or sour cream will break down if heated above boiling point, carefully stir them in at end of cooking cycle.

## Meats

- For meats, trim fats, wipe or rinse well, and pat dry with paper towels. Browning meat in a separate skillet or broiler allows fat to be drained off before slow cooking and also adds greater depth of flavor to dish.
- Larger roasts, chickens, and hams are the perfect size for your slow cooker. Select boneless roasts or hams ranging from 2 to 4 pounds for a 4-quart slow cooker, 2.5 to 5 pounds for a 5-quart slow cooker, and 3 to 6 pounds for a 6-quart slow cooker.
- Bone-in cuts like ribs, loin cuts, or turkey pieces fit easily and cook well in your slow cooker. Cook turkey legs, thighs, and breasts, up to 4 pounds for 4-quart slow cookers, 5 pounds for 5-quart slow cookers, and 6 pounds for 6-quart slow cookers.
- If you select a smaller roast, alter the amount of vegetables or potatoes so that the stoneware is  $\frac{1}{2}$  to  $\frac{3}{4}$  full.



- Always remember, the size of the meat and the recommended cook time are just estimates. The exact weight of a roast that can be cooked in the slow cooker will depend upon the specific cut, meat configuration, and bone structure.
- Cut meat into smaller pieces when cooking with precooked beans, fruit, or lighter vegetables such as mushrooms, diced onion, eggplant, or finely minced vegetables. This will enable food to cook at the same rate.
- Lean meats such as chicken or pork tenderloin will cook faster than meats with more connective tissue and fat such as beef chuck or pork shoulder.
- Meat should be positioned so that it rests in the stoneware and does not touch the lid.
- If you are cooking frozen meats (such as roasts or chickens), you must first add at least 1 cup of warm liquid. The liquid will act as a “cushion” to prevent sudden temperature changes. For most recipes containing cubed frozen meat, cook meats an additional 4 hours on LOW or 2 hours on HIGH. For large cuts of frozen meat, it may take much longer to defrost and tenderize.

## Fish

- Fish cooks quickly and should be added at the end of the cooking cycle, during last fifteen minutes to hour of cooking.

## Specialty Dishes

- Specialty dishes, such as stuffed chops or steak rolls, stuffed cabbage leaves, stuffed peppers, or baked apples can be arranged in a single layer so they cook evenly and serve attractively.

Visit the Crock-Pot® website at [www.crock-pot.ca](http://www.crock-pot.ca), for additional Hints and Tips, Questions and Answers, and Recipes.

## Auto Program Chart

The auto programs are designed to give you the greatest ease in programming for classic slow cooker dishes. The Main Courses chapter offers several recipes for each program (pg. 34). The chart on the following page indicates the total cook time for each Auto Cook program. The program will automatically switch to WARM once the cycle has been completed.

MEAT CUT	DISPLAY	MEAT WEIGHT	TOTAL COOK TIME LOW	TOTAL COOK TIME HIGH
Pork 1 (bone-in)	PRK1	6-7 pounds	9½ hours	7½ hours
Pork 2 (boneless)	PRK2	3-4 pounds	6 hours	5 hours
Poultry	POUL	6 pounds	7½ hours	6¼ hours
Beef	BEEF	3-4 pounds	8 hours	5¾ hours
Stew	STEW	3 pounds	6 hours	4¾ hours
Chili	CHIL	1-3 pounds	6½ hours	6 hours

## Converting Your Recipes

When setting your slow cooker, you always have the flexibility to cook faster or slower by choosing the HIGH or LOW setting. When converting your own recipes, refer to the chart below which offers suggested cook times for typical slow cooker dishes. Remember, this is just a guide. Specific times are dependant upon quantity, cut of meat, and additional liquids and ingredients. Normally, it takes approximately 3-4 hours on HIGH and approximately 7-8 hours on LOW for many slow cooked meat dishes to reach the simmer point. After that time, most slow cooked meats just begin to tenderize and may take an additional time to become a “fall-off-the-bone” consistency.

LOW	HIGH
7 hours	3 hours
8 hours	4 hours
9 hours	5 hours
10 hours	6 hours
11 hours	7 hours
12 hours	8 hours

## Smart-Set™ Recipes

### **Brunch and Beverages** ..... E21

<i>Breakfast Berry Bread Pudding</i> .....	E21
<i>Bacon and Eggs Primavera</i> .....	E22
<i>Fruity Granola Oatmeal</i> .....	E23
<i>Fruit Medley Compote</i> .....	E24
<i>Spiced Chai Tea</i> .....	E25
<i>Mulled Cider</i> .....	E25

### **Appetizers and Side Dishes** ..... E26

<i>Asian-Style Ribs</i> .....	E26
<i>Stuffed Mushrooms</i> .....	E27
<i>Teriyaki Chicken Wings</i> .....	E28
<i>Sesame Pork Fire Bites</i> .....	E28
<i>Wild Rice with Fruit and Nuts</i> .....	E29
<i>Butternut Squash Risotto</i> .....	E30
<i>Asparagus in Parchment Paper Package</i> .....	E31
<i>Quinoa with Mixed Berries</i> .....	E32
<i>Garlic Mashed Potatoes</i> .....	E32
<i>Creamy Parmesan Polenta</i> .....	E33

### **Main Courses**..... E34

#### **Poultry** ..... E34

<i>Mediterranean Memories</i> .....	E34
<i>Three Bean Turkey Chili</i> .....	E35
<i>Chicken Pot Au Feu</i> .....	E36
<i>Creamy Roasted Chicken and Prosciutto</i> .....	E37
<i>Burgundy Braised Chicken</i> .....	E38
<i>Spinach and Feta Stuffed Chicken Breasts</i> .....	E40
<i>Chicken and Artichokes</i> .....	E41
<i>Chicken with Shallots and White Wine</i> .....	E42
<i>Curry Chicken with Peaches and Raisins</i> .....	E43

**Pork and Sausage**..... E45

*Pulled Pork Sandwiches* ..... E45  
*Easy Pork Burritos* ..... E46  
*Sweet and Spicy Pork Picadillo*..... E47  
*Pork Tenderloin with Figs, Apricots,  
and Shitake Mushrooms* ..... E48  
*Smothered Autumn Pork Roast* ..... E49  
*Boneless Pork Roast with Garlic and Rosemary* ..... E50  
*Country-Style Pork Ribs* ..... E51  
*Baby Back Ribs* ..... E52  
*Beer-Braised Kielbasa* ..... E52  
*Sausage and Pepper Submarine Sandwiches* ..... E53

**Beef**..... E54

*Maple Whiskey Glazed Beef Brisket* ..... E54  
*Carne Relleno* ..... E55  
*Hearty Beef Short Ribs* ..... E56  
*Beef Ale Stew with Caramelized  
Onions and Fennel* ..... E57  
*Winter Comfort Pot Roast* ..... E58  
*Simple Korean Flank Steak* ..... E59  
*Six Pepper Chili* ..... E60  
*Beef, Bacon, and Mushroom Stew* ..... E61

**Vegetarian** ..... E63

*Chunky Vegetarian Chili* ..... E63  
*Mushroom Barley Stew* ..... E64  
*Easy Pizza or Pasta Sauce* ..... E65

## **Soups and Chowders**.....E66

<i>Black Bean Chipotle Soup</i> .....	E66
<i>Curried Butternut Squash Soup</i> .....	E67
<i>Chicken Tortilla Soup</i> .....	E68
<i>Beggar's Chowder</i> .....	E69
<i>Shrimp Thai Soup with Lime and Chilies</i> .....	E70
<i>New England Clam Chowder</i> .....	E71
<i>Split Pea Soup</i> .....	E72

## **Holidays and Special Occasions**.....E72

<i>Stuffed Artichokes</i> .....	E72
<i>Duck with Port, Mushroom, and Tart Cherry Glaze</i> .....	E73
<i>Home-Style Cornbread</i> .....	E74
<i>Corned Beef and Cabbage</i> .....	E75
<i>Stuffing with Apples, Canadian Bacon, and Toasted Pecans</i> .....	E76
<i>Citrus Spark Salmon Steaks</i> .....	E77
<i>Holiday Ham with Ginger and Bourbon</i> .....	E78
<i>Turkey with Pecan-Cherry Stuffing</i> .....	E78
<i>Sweet Potato Casserole with Gingersnap Topping</i> .....	E79
<i>Lamb Stew with Sherry and Thyme</i> .....	E80
<i>Scalloped Potatoes and Ham</i> .....	E81

## **Desserts**.....E82

<i>Crème Brûlée</i> .....	E82
<i>Chocolate Polenta Cake</i> .....	E83
<i>Apple Butter</i> .....	E84
<i>Orange Soufflé</i> .....	E85
<i>Cinnamon Ginger Poached Pears</i> .....	E86

## Brunch and Beverages

### *Breakfast Berry Bread Pudding*

- 1 tablespoon butter
- 8 cups 1-inch cubed bread, preferably dense loaf of Italian, sourdough, or peasant loaf
- 3 cups sliced, fresh strawberries\*
- 2 cups fresh blueberries\*
- 7 large eggs, beaten
- 5-7 cups milk (1% or greater) - use 5 if cooking on LOW
- 2 tablespoons vanilla extract
- 1½ cups brown sugar (increase to 2 cups if making bread pudding for dessert)
- 2½ tablespoons cinnamon

*\*If you are making this dish during a season when fresh berries are not available, a combination of mixed unsweetened frozen berries can be substituted (strawberries, raspberries, blackberries and blueberries). Thaw berries before using or extend the cooking time slightly if using berries directly from the freezer.*

1. Butter the inside of the stoneware.
2. Place the bread and berries into the stoneware and toss to combine.
3. Combine the remainder of the ingredients in a separate bowl and whisk to blend.
4. Pour over bread and berries, and toss to blend.
5. Cover; cook on LOW for 5-6 hours or on HIGH for 3 hours, until the bread has set in the middle.
6. Remove from heat. Allow to cool and set prior to serving (this will allow the bread to reabsorb to liquid from the berries, etc.).

Serves 10-12



This recipe is ideal for using the Auto Cook Mode. Refer to pg. 7 for instructions.

E21



This recipe is ideal for using the Dual Cycle Mode. Refer to pg. 10 for instructions.

## Bacon and Eggs Primavera

*Non-stick cooking spray*

*3-4 cups diced crusty bread (¾-1 inch dices)*

*½ pound bacon, cut into ½-inch dices*

*2 cups sliced fresh mushrooms (about 6-ounces of whole mushrooms), such as Crimini or Baby Bellas*

*2 cups sliced fresh spinach, stems removed*

*8 eggs*

*½ cup milk*

*¾ cup roasted red peppers, drained and chopped*

*1 cup shredded cheese, such as Cheddar or Monterey Jack*

*Salt and pepper*

1. Spray the stoneware with non-stick spray.
2. Pour bread into bottom of stoneware.
3. Heat a sauté pan on medium heat and cook bacon until crispy. Remove all but 1 tablespoon of renderings. Add mushrooms and spinach and toss to coat. Cook for 1-2 minutes, until spinach wilts.
4. In a separate bowl, beat eggs and milk. Add remaining ingredients and blend. Pour into stoneware.
5. Cover; cook on LOW for 3½-4 hours or on HIGH for 2½ hours, until eggs are firm in center but still moist.
6. Season with salt and pepper, and serve.

Serves 6-8



This recipe is ideal for using the Auto Cook Mode. Refer to pg. 7 for instructions.

E22



This recipe is ideal for using the Dual Cycle Mode. Refer to pg. 10 for instructions.

# Fruity Granola Oatmeal



*Nonstick cooking spray or butter for coating stoneware*

*1/4 cup old fashioned oats (not quick cooking)*

*1 cup plain, cinnamon, or apple granola*

*2 cups milk, plus more if desired for serving*

*1 cup water*

*1/4 teaspoon salt*

*1 teaspoon cinnamon*

*1/4 cup apples, peeled, cored, and chopped into 1-inch cubes*

*1/4 cup pears, peeled, cored, and chopped into 1-inch cubes*

*1/4 cup walnuts, toasted*

*1/4 cup maple syrup or brown sugar (optional)*

1. Grease stoneware with cooking spray or butter.
2. Add oats, granola, milk, water, salt, cinnamon, and fruit to stoneware. Gently stir ingredients.
3. Cover; cook on HIGH for 2 hours and then on LOW for 1-2 hours.
4. On a large baking sheet, toast walnuts on the top rack of the broiler for about 4 minutes. Turn frequently.
5. Mix walnuts into stoneware.
6. Spoon oatmeal into individual bowls and serve hot. Add additional milk, maple syrup and brown sugar if desired.

Serves 6-8



This recipe is ideal for using the Auto Cook Mode. Refer to pg. 7 for instructions.

E23



This recipe is ideal for using the Dual Cycle Mode. Refer to pg. 10 for instructions.



## Fruit Medley Compote

- 1 cup water
- 1 cup sugar or to desired sweetness
- ½ cup brown sugar
- 2 pounds fresh rhubarb stalks, washed and cut into 2-inch cubes
- 1 quart fresh strawberries, rinsed, hulled, and halved
- 2 cups fresh raspberries
- 2 cups fresh blueberries
- 2 teaspoons vanilla
- 1½ teaspoons ground cinnamon
- ¼ teaspoon ground nutmeg

1. Combine water, sugars, and rhubarb in stoneware.
2. Cover; cook on HIGH for 30 minutes.
3. Add strawberries, raspberries, and blueberries to stoneware.
4. Add vanilla, cinnamon, and nutmeg to fruit. Gently stir fruit once or twice to evenly distribute and return cover to stoneware.
5. Remove stoneware from heating base, and allow mixture to cool without stirring. Compote can be served warm, at room temperature, or refrigerated. If not using immediately, place in storage bowl, cover, and refrigerate. Compote can remain in refrigerator for up to four days.

*Serving suggestions: serve on top of French toast, waffles, yogurt, ice cream, pound cake, or Fruity Granola Oatmeal. (pg. 23)*

Serves 8-10



This recipe is ideal for using the Auto Cook Mode. Refer to pg. 7 for instructions.

E24



This recipe is ideal for using the Dual Cycle Mode. Refer to pg. 10 for instructions.

## Spiced Chai Tea

2 quarts water  
8 bags black tea  
 $\frac{1}{2}$  -  $\frac{3}{4}$  cup sugar  
16 whole cloves  
16 whole cardamom seeds, pods removed  
5 whole cinnamon sticks  
8 slices fresh ginger  
1 cup milk

1. Combine water, tea, sugar, cloves, cardamom, cinnamon, and ginger in the stoneware. Cover; cook on LOW for 3-5 hours or on HIGH for 2-2½ hours.
2. Strain mixture; discard solids. (May be covered and refrigerated for up to 3 days.)
3. Stir in milk just before serving. Serve warm or chilled.

Serves 16

## Mulled Cider



1 gallon apple cider  
 $\frac{1}{3}$  cup brown sugar  
15 whole cloves  
10 whole allspice berries  
5 whole cinnamon sticks

1. Combine all ingredients in the stoneware.
2. Cover; cook on HIGH for 30 minutes and then on LOW for up to 5 hours. The longer the spices are left in, the stronger the “mulling.”

Serves 16



This recipe is ideal for using the Auto Cook Mode. Refer to pg. 7 for instructions.

E25



This recipe is ideal for using the Dual Cycle Mode. Refer to pg. 10 for instructions.

## Appetizers and Side Dishes

### *Asian-Style Ribs*



*2 full racks baby back pork ribs*  
*6 ounces Hoisin sauce*  
*1 ounce fresh ginger*  
*4 ounces of maraschino cherries*  
*4 ounces of rice wine vinegar*  
*Water to cover*  
*Chopped scallions*

1. Split each rack of ribs into three sections.
2. Combine all ingredients in stoneware.
3. Cover; cook on LOW for 8 to 10 hours or on HIGH for 6 to 8 hours.
4. Garnish with scallions.

Serves 6-8



This recipe is ideal for using the Auto Cook Mode. Refer to pg. 7 for instructions.

E26



This recipe is ideal for using the Dual Cycle Mode. Refer to pg. 10 for instructions.

## Stuffed Mushrooms

- 15-20 large mushrooms, preferably Baby Bellas, cleaned, stems removed and finely chopped*
- 2 tablespoons olive oil*
- ½ medium red onion, very finely diced*
- 2 cloves garlic, minced*
- ½ pound sausage patties*
- 1 teaspoon salt*
- ½ teaspoon ground black pepper*
- ¼ teaspoon paprika*
- ¼ cup fresh parsley, finely chopped*
- 4 ounces Gruyere cheese, shredded*

1. In a skillet over medium heat, add the oil, onion, garlic, and mushroom stems. Cook for 2-3 minutes, until onion begins to soften.
2. Add the sausage patties and crumble with a wooden spoon. Season with salt, pepper, and paprika, and cook until lightly browned through.
3. Transfer the sausage to a heavy mixing bowl along with the parsley and Gruyere cheese. Stir to combine ingredients and stuff 1 tablespoon of mixture into each cap. Place into the stoneware, cover and cook on HIGH for 2 hours.

Serves 6-10



This recipe is ideal for using the Auto Cook Mode. Refer to pg. 7 for instructions.

E27



This recipe is ideal for using the Dual Cycle Mode. Refer to pg. 10 for instructions.

## Teriyaki Chicken Wings

---

3-4 pounds chicken wings  
¼ cup soy sauce  
¼ cup sherry  
¼ cup honey  
1 tablespoon Hoisin sauce  
1 tablespoon orange juice  
2 cloves garlic, minced  
1 red chili pepper, minced (optional)

1. Place the wings in the stoneware. Combine remaining ingredients in a bowl and pour over the wings.
2. Cover; cook on LOW for 3-3½ hours or on HIGH for 1½-2 hours.

Serves 6-8

## Sesame Pork Fire Bites

---

3 pounds pork loin, cut into ¾-inch cubes  
1 4-ounce can sliced green chilies, drained  
½ cup soy sauce  
2 tablespoons cornstarch  
¼ cup brown sugar, packed  
¼ cup apple juice  
2 tablespoons rice vinegar  
1 tablespoon sesame seeds  
2 cloves garlic, minced  
¼ teaspoon ground ginger

1. With a small, sharp knife, make a slit into a pork cube and stuff it with a sliced green chili. Insert a toothpick through the top to hold the chili in place. Repeat with remaining pork and place in bottom of the stoneware.
2. In a bowl, dissolve the cornstarch into the soy sauce. Stir in the remaining ingredients, and pour over the pork. Cover; cook on LOW for 3-3½ hours or on HIGH for 1½-2 hours.

Serves 6-8



This recipe is ideal for using the Auto Cook Mode. Refer to pg. 7 for instructions.

E28



This recipe is ideal for using the Dual Cycle Mode. Refer to pg. 10 for instructions.

## *Wild Rice with Fruit and Nuts*

---

2 cups wild rice, rinsed\*  
5-6 cups chicken broth  
1 cup orange juice  
2 tablespoons butter, melted  
½ cup dried cranberries  
½ cup raisins, chopped  
½ cup chopped dried apricots  
½ cup almond slivers, toasted  
1 teaspoon cumin  
2 scallions, thinly sliced  
2-3 tablespoons chopped fresh parsley  
Salt and pepper

*\*If using a wild rice blended with other types of rice, cooking time may be shortened.*

1. Combine wild rice, cranberries, raisins, apricots and almonds in the stoneware.
2. Combine broth, orange juice, butter and cumin in medium bowl. Pour mixture over rice, and stir to mix.
3. Cover; cook on LOW for 7 hours or on HIGH for 2½-3 hours. Stir once, adding more hot broth if necessary.
4. When rice is soft to the bite, add scallions and parsley. Adjust seasonings. Cook for 10 additional minutes and serve.

Serves 6-8



This recipe is ideal for using the Auto Cook Mode. Refer to pg. 7 for instructions.

E29



This recipe is ideal for using the Dual Cycle Mode. Refer to pg. 10 for instructions.

## Butternut Squash Risotto

4 tablespoons extra virgin olive oil  
4 tablespoons unsalted butter  
1½ cups Vidalia onion, chopped  
2½ cups risotto rice such as superfino Arborio  
3 cups butternut squash, peeled, seeded, and cut into 1-inch cubes  
6 cups chicken broth  
2 tablespoons fresh basil, chopped  
¼ cup Pecorino Romano cheese plus extra for sprinkling on top  
Salt and pepper

1. In skillet, over medium heat, add oil and butter, and sauté until tender, approximately 6-8 minutes.
2. Pour rice on top of onions and, with a wooden spoon, coat grains with butter and oil mixture. Cook and occasionally stir for about 4 minutes.
3. Transfer rice to stoneware. Add squash and broth and gently stir ingredients. Cover; cook on HIGH for 2-3 hours.
4. When serving, top with basil and additional cheese if desired. Season to taste with salt and freshly cracked black pepper.

Serves 10-12



This recipe is ideal for using the Auto Cook Mode. Refer to pg. 7 for instructions.

E30



This recipe is ideal for using the Dual Cycle Mode. Refer to pg. 10 for instructions.

## *Asparagus in Parchment Paper Package*

*Parchment paper*

*1 bunch asparagus, bottom ends trimmed*

*Salt and pepper*

*Pinch sugar*

*Lemon zest*

*Drizzle of extra virgin olive oil*

1. Cut parchment paper into large heart shape. Place asparagus in center of one side. Season with salt and pepper. Sprinkle with sugar and lemon zest, and drizzle with olive oil.
2. Turn heart half over asparagus, folding along center. Turn, crimp, and fold edges to seal.
3. Place in stoneware. Cover; cook on HIGH for 1 hour, checking doneness after  $\frac{1}{2}$  hour, until asparagus spears are bright green and just tender. Open pouch and serve immediately.

Serves 4



This recipe is ideal for using the Auto Cook Mode. Refer to pg. 7 for instructions.

E31



This recipe is ideal for using the Dual Cycle Mode. Refer to pg. 10 for instructions.



## *Quinoa with Mixed Berries*

---

3 cups imported quinoa  
4 cups orange juice  
¼ brown sugar  
2 tablespoon butter  
Pinch of salt  
½ cup dried cranberries  
½ cup dried blueberries  
1 teaspoon cinnamon  
1 teaspoon orange zest  
½ cup macadamia nuts, toasted and coarsely chopped

1. Place quinoa in large bowl, fill with cold water, and massage between fingers. Drain in fine strainer, and repeat this process three more times or until there is no foam.
2. Transfer quinoa to stoneware; add juice, brown sugar, butter, and salt. Gently swirl to mix ingredients. Cover; cook on HIGH for 1½ - 2 hours.
3. Before serving, mix in dried fruit, cinnamon, zest, and nuts.

Serves 8-10

## *Garlic Mashed Potatoes*

---

4 pounds potatoes, cut  
4-6 cloves garlic, peeled  
3 cups chicken broth, vegetable broth or water  
1 stick butter, cut in small pieces  
½ cup heavy cream  
Salt and pepper to taste

1. Place potatoes and garlic in stoneware. Pour enough broth in stoneware to cover potatoes. Cover; cook on HIGH for 4-5 hours or until potatoes are tender.
2. Drain broth and add butter and cream and mash with a potato masher until desired consistency.
3. Season with salt and pepper and serve warm.

Serves 8-10



This recipe is ideal for using the Auto Cook Mode. Refer to pg. 7 for instructions.

E32



This recipe is ideal for using the Dual Cycle Mode. Refer to pg. 10 for instructions.

## *Creamy Parmesan Polenta*

---

*9 cups chicken broth or water*  
*4 tablespoons butter*  
*1 bay leaf*  
*3 cups instant polenta*  
*3 cups grated parmesan*

1. In a pot on the stovetop, bring the chicken broth or water to a boil with the butter and bay leaf.
2. Whisk in the polenta in a steady stream to prevent lumps. Whisk in the grated cheese to fully combine.
3. Turn the polenta out into the stoneware, cover, and cook on LOW for 25-30 minutes.

Serves 6-8



This recipe is ideal for using the Auto Cook Mode. Refer to pg. 7 for instructions.

E33



This recipe is ideal for using the Dual Cycle Mode. Refer to pg. 10 for instructions.

# Main Courses

## Poultry:

### *Mediterranean Memories*



*Non-stick cooking spray*

*1 bulb fennel (about 1-1¼ pounds), trimmed, quartered, and sliced; reserve some 'fennel fronds' for garnish, if desired*

*1 large onion, chopped*

*2 carrots, finely chopped*

*2 garlic cloves, minced*

*1 teaspoon salt - divided usage*

*1 teaspoon coarsely ground black pepper - divided usage*

*8 boneless, skinless chicken thighs, all visible fat removed (about 1½ pounds)*

*2 14-ounce cans chicken broth*

*1 cup orzo*

*1 6-ounce bag of baby spinach (about 4 cups)*

*½ cup coarsely shredded Asiago cheese*

1. Lightly spray stoneware with cooking spray. Place fennel, onion, carrot, and garlic in stoneware; stir in about half of the salt and pepper; spread mixture evenly over bottom of stoneware.
2. With kitchen shears or knife, cut each chicken thigh into 4-6 pieces. Season chicken chunks with remaining salt and pepper. Place chicken atop fennel/onion mixture. Pour chicken broth over top.
3. Cover; cook on HIGH for 1 hour and then on LOW for 2 hours.
4. Stir in orzo; cover and cook on LOW for 1½ hours more. Check to see if orzo and chicken are tender; if necessary cook about 30 minutes longer.
5. Place spinach atop chicken/orzo mixture; do not stir. Cover and continue to cook on LOW for 10 to 15 minutes. Turn off heat. Stir spinach into chicken/orzo mixture. If desired, garnish with some of the reserved feathery fennel fronds. Top each serving with Asiago cheese.

Serves 6-8



This recipe is ideal for using the Auto Cook Mode. Refer to pg. 7 for instructions.

E34



This recipe is ideal for using the Dual Cycle Mode. Refer to pg. 10 for instructions.

## Three Bean Turkey Chili



Olive oil

1 pound ground turkey

1 small onion, chopped

1 28-ounce can diced tomatoes, undrained

1 15-ounce can garbanzo beans, rinsed and drained

1 15-ounce can kidney beans, rinsed and drained

1 15-ounce can black beans, rinsed and drained

1 8-ounce can tomato sauce

1 4-ounce can chopped mild green chilies

1-2 tablespoons chili powder

1. Cook turkey and onion in medium skillet coated with olive oil over medium-high heat, stirring to break up meat, until turkey is no longer pink.
2. Drain; place turkey mixture into the stoneware.
3. Add tomatoes with juice, beans, tomato sauce, chilies, and chili powder; mix well.
4. Cover; cook on LOW for 6-8 hours or on HIGH for 5-7 hours.

Serves 6-8



This recipe is ideal for using the Auto Cook Mode. Refer to pg. 7 for instructions.

E35



This recipe is ideal for using the Dual Cycle Mode. Refer to pg. 10 for instructions.

## Chicken Pot Au Feu



- 1 16-ounce bag baby carrots
- 1 large onion, cut in quarters
- 4 medium celery stalks, cut into 1-inch pieces
- 4 new potatoes, quartered
- 2 3-pound whole chickens or one 1 6-pound chicken
- 1 10-ounce box of mushrooms, cleaned
- 1½ teaspoons salt
- 1 teaspoon freshly ground black pepper
- ½ cup water, white wine or chicken broth
- 3 sprigs fresh thyme

1. Place the carrots, onion, celery, and potatoes in the bottom of the stoneware.
2. Add the whole chicken(s) and top with the remaining ingredients.
3. Cover; cook on LOW for 8-10 hours or on HIGH for 4½-6½ hours.
4. Remove the chicken and vegetables, and arrange attractively on a platter before serving.

Serves 6-8



This recipe is ideal for using the Auto Cook Mode. Refer to pg. 7 for instructions.

E36



This recipe is ideal for using the Dual Cycle Mode. Refer to pg. 10 for instructions.

## Creamy Roasted Chicken and Prosciutto



*2½ pounds whole chicken, seasoned with salt and pepper*  
*1 small onion, finely chopped*  
*5 ounces prosciutto or bacon, diced*  
*½ cup dry white wine*  
*1 10-ounce package frozen peas*  
*½ cup heavy cream*  
*1½ tablespoons cornstarch*  
*2 tablespoons water*  
*4 cups bowtie pasta, cooked al dente*

1. Combine the chicken, onion, prosciutto, and wine in the stoneware. Cover; cook on LOW for 7-9 hours or on HIGH for 4½- 6½ hours.
2. In the last 30 minutes of cooking, add the frozen peas and the heavy cream to the liquid in the stoneware.
3. After cooking, remove the chicken from the stoneware and carve the meat in slices.
4. Combine the cornstarch and water and add to the liquid in the slow cooker to thicken the sauce.
5. To serve, spoon the pasta onto individual plates, place the chicken over the pasta, and top each portion with sauce.

Serves 6



This recipe is ideal for using the Auto Cook Mode. Refer to pg. 7 for instructions.

E37



This recipe is ideal for using the Dual Cycle Mode. Refer to pg. 10 for instructions.

## Burgundy Braised Chicken



2 whole chickens, 3 pounds each  
5 cups red wine  
8 strips bacon, cut into 1/2-inch strips  
8 sprigs thyme  
6 garlic cloves, peeled and sliced thin  
4 cups quartered button mushrooms  
4 cups thinly sliced onions  
2 tablespoons butter  
1/2 cup flour  
2 cups chicken broth  
1 bunch Italian flat leaf parsley, washed, stemmed, and coarsely chopped  
Salt and pepper  
Creamy Parmesan Polenta (pg. 33)

1. The day before cooking the dish: Quarter the chicken, leaving the breasts on the bone. Separate each leg into thigh and drumstick portions, and cut each breast in half.
2. Add the chicken to a shallow container large enough to accommodate all of the pieces in a single layer. Pour the wine over the chicken and add the thyme and sliced garlic.
3. Cover and marinate in refrigerator overnight.
4. Cook the bacon in a sauté pan until crispy. Remove bacon with a slotted spoon to a plate lined with paper towels, leaving all of the rendered fat in the pan.
5. Add the mushrooms to the pan and sauté until lightly golden brown. Toss the onions into the mushrooms and continue to sauté until they are well caramelized.
6. Reduce the heat to LOW and melt in the butter and then incorporate the flour. Continue to cook for 5 minutes, then season with salt and pepper and remove from the heat.
7. Remove the chicken from the marinade, season with salt and pepper, and dust the skin sides lightly with flour.

Recipe continued on next page.



This recipe is ideal for using the Auto Cook Mode. Refer to pg. 7 for instructions.

E38



This recipe is ideal for using the Dual Cycle Mode. Refer to pg. 10 for instructions.

## Burgundy Braised Chicken (cont.)



8. Sauté the pieces of chicken, skin side down, until golden brown and then add to the slow cooker stoneware.
9. Add the red wine marinade to a sauce pot and slowly bring to a simmer. Simmer for a few minutes, skimming away impurities that rise to the top.
10. Add the chicken broth, caramelized onion, and mushroom mixture to the wine and heat through. Adjust seasoning and then pour over the chicken.
11. Cover the slow cooker and cook on HIGH for 30 minutes.
12. Reduce the temperature setting to LOW and cook for 2 more hours.
13. Serve the chicken over Creamy Parmesan Polenta (Pg. 33), spooning sauce over.
14. Garnish with the crisp bacon and parsley.

Serves 4-6



This recipe is ideal for using the Auto Cook Mode. Refer to pg. 7 for instructions.

E39



This recipe is ideal for using the Dual Cycle Mode. Refer to pg. 10 for instructions.



## *Spinach and Feta Stuffed Chicken Breasts*

6 boneless, skinless chicken breasts  
8 ounces Feta cheese (drained and dried if necessary)  
3 cups chopped fresh spinach (heavy stems removed)  
 $\frac{1}{2}$  cup sun-dried tomatoes, drained from oil and chopped (if using dry sun dried tomatoes, soak in warm water for 10-15 minutes, dry and chop)  
 $\frac{1}{2}$  cup oil cured olives, pit in\*  
1 teaspoon minced lemon zest  
1 teaspoon dried basil, oregano or mint  
 $\frac{1}{2}$  teaspoon garlic powder  
1 15-ounce can of diced tomatoes, undrained  
Freshly ground black pepper

*\*If using pitted olives, add to stoneware in the final hour of cooking.*

1. Place 1 chicken breast between plastic wrap and, using the back of a skillet or meat tenderizer, pound until about  $\frac{1}{4}$ -inch thin. Repeat with each.
2. In a separate bowl, combine Feta, spinach, sun dried tomatoes, lemon zest, basil (or oregano or mint), garlic powder, and pepper to taste. Mix to combine.
3. Lay "skin" side down on work surface and place approximately 2 tablespoons of feta mixture onto the wide end of the breast. Roll snugly and repeat with each.
4. Place rolled chicken in stoneware, seam down, and top with diced tomatoes and olives.
5. Cover; cook on LOW for  $3\frac{1}{2}$ -4 hours or on HIGH for  $2\frac{1}{2}$  hours. Serve each portion topped with a spoonful of tomatoes and olives.

Serves 6



This recipe is ideal for using the Auto Cook Mode. Refer to pg. 7 for instructions.

E40



This recipe is ideal for using the Dual Cycle Mode. Refer to pg. 10 for instructions.

## Chicken and Artichokes



3 pounds boneless, skinless chicken thighs  
16 ounces fresh mushrooms, sliced  
2 12-ounce jars marinated artichoke hearts, drained  
8 cloves garlic, peeled and coarsely chopped  
½ cup white wine (or chicken broth)  
Black pepper  
1-2 pounds spaghetti, cooked

1. Place chicken, mushrooms, artichokes, garlic, wine and black pepper into stoneware.
2. Cover; cook on LOW for 6-8 hours or on HIGH for 5½-6½ hours.
3. Serve over pasta.

Serves 6-8



This recipe is ideal for using the Auto Cook Mode. Refer to pg. 7 for instructions.

E41



This recipe is ideal for using the Dual Cycle Mode. Refer to pg. 10 for instructions.

## *Chicken with shallots and White Wine*

8-10 boneless, skinless chicken thighs, rinsed, dried and seasoned with salt and pepper

4 large Yukon Gold potatoes, cut into  $\frac{3}{4}$  - 1 inch cubes

10 ounces Spanish green olives (pit in), drained and rinsed\*

12 shallots, skinned and sliced in  $\frac{1}{2}$  (across the shallot)

8 sprigs of fresh tarragon or 2 tablespoons dried tarragon

8 cloves of garlic, crushed

$\frac{3}{4}$  cup white wine

$\frac{3}{4}$  cup chicken stock

$1\frac{1}{2}$  tablespoons Dijon mustard

Salt and pepper

*\*If using pitted olives, add to stoneware in the final hour of cooking.*

1. Add chicken, shallots, olives, and tarragon to stoneware.
2. Combine all remaining ingredients except Dijon mustard. Whisk to blend and pour into stoneware.
3. Cover; cook on LOW for 6 hours or on HIGH for 4 hours, turning once or twice if possible to ensure even cooking.
4. Once shallots have softened, transfer chicken, shallots, olives, and potatoes to a serving dish and cover to keep warm.
5. Set slow cooker to HIGH, whisk in the Dijon mustard and continue to cook for 15 minutes, allowing the broth to simmer.
6. Adjust seasoning, pour broth over chicken, shallots, olives, and potatoes and serve.

Serves 4



This recipe is ideal for using the Auto Cook Mode. Refer to pg. 7 for instructions.

E42



This recipe is ideal for using the Dual Cycle Mode. Refer to pg. 10 for instructions.

## Curry Chicken with Peaches and Raisins\*

8-10 boneless, skinless chicken thighs, rinsed, dried and seasoned with salt and pepper  
4 peaches, skinned and sliced into 1/4-inch slices, reserving 6 slices for garnish (or 2 cups frozen sliced unsweetened peaches, with 6 slices reserved for garnish)\*\*  
2/3 cup raisins, chopped, OR 2/3 cup currants, whole  
2 shallots, thinly sliced  
2 tablespoons olive oil  
2 tablespoons fresh ginger root, grated  
4 cloves of garlic, crushed  
1 teaspoon curry  
2 teaspoons cumin  
1 teaspoon whole cloves  
1/2 cup chicken stock  
2 tablespoons cider vinegar  
1/2 teaspoon cayenne pepper (optional)  
Salt and pepper  
Lemon juice

\*If making this dish during a season that fresh peaches are not available, unsweetened frozen peeled sliced peaches can also be used. Thaw peaches before using or extend the cooking time if using peaches straight from the freezer.

\*\*To skin a peach, use a peeler OR make an "x" at the bottom of the peach with a knife, submerge the peach into simmering water for 10-20 seconds. Cool under running water or in an ice water bath. When cool enough to handle, use paring knife to peel away skin.

1. Rinse, dry and season the chicken with salt and pepper.
2. Heat the olive oil in a skillet and add the chicken to lightly brown, about 3 minutes per side.
3. Transfer chicken to stoneware and top with peaches, raisins, (or whole currants) and shallots.

Recipe continued on next page.



This recipe is ideal for using the Auto Cook Mode. Refer to pg. 7 for instructions.

E43



This recipe is ideal for using the Dual Cycle Mode. Refer to pg. 10 for instructions.

## *Curry Chicken with Peaches and Raisins (cont.)*

---

4. Reserve the remaining 8 slices of peaches tossed with lemon juice to coat and refrigerate.
5. Combine remaining ingredients in a bowl, whisk to combine and pour over chicken.
6. Cook on LOW for 5-7 hours or on HIGH for 3-5 hours.
7. Remove chicken to serving dish. Using a slotted spoon, spoon the peaches, raisins (or currants), and some of the juice onto the chicken and serve. Garnish with the reserved peaches.

Serves 4-5



This recipe is ideal for using the Auto Cook Mode. Refer to pg. 7 for instructions.

E44



This recipe is ideal for using the Dual Cycle Mode. Refer to pg. 10 for instructions.

## Pork and Sausage:

### *Pulled Pork Sandwiches*



#### Sauce:

5 cloves chopped garlic  
2 cups orange juice  
2 cups coffee  
2 cups brown sugar  
16 ounces ketchup  
3 cups balsamic vinegar  
1 cup molasses  
2 teaspoons ground cinnamon  
1/2 teaspoon ground cloves  
2 cans beer

6 pounds pork butt or pork shoulder  
10 cloves garlic  
Salt and freshly ground pepper  
8 Rolls

1. Combine all ingredients for the sauce in a large saucepan and bring to a simmer. Continue to cook for 45 minutes at a low simmer, stirring occasionally to keep the sugars from scorching on the bottom of the pan.
2. Preheat oven to 425°F.
3. Using a small paring knife, cut deep slits into the pork and insert the garlic cloves all around. Rub the pork with oil and season liberally with salt and freshly ground pepper. Place the pork on a rack and put in the oven for 25 minutes. The high heat will sear the pork all around and give a nice crust.
4. Place the pork in the stoneware and cover with the sauce. Cover; cook on LOW for 10-12 hours or on HIGH for 7 to 9 hours.
5. Stuff rolls with pulled pork.

Serves 8



This recipe is ideal for using the Auto Cook Mode. Refer to pg. 7 for instructions.

E45



This recipe is ideal for using the Dual Cycle Mode. Refer to pg. 10 for instructions.

## Easy Pork Burritos



*1 6-pound pork butt or pork shoulder, trimmed of fat*  
*1-2 bottles of your favorite BBQ sauce*  
*1 package (8) burrito wrappers*  
*2 ripe avocados, peeled and sliced*  
*1 bunch cilantro, stemmed (optional)*  
*1-2 cups shredded Monterey Jack or Cheddar cheese*  
*Sour cream and salsa to garnish*

1. Place pork in stoneware. Cover; cook on LOW for 10-12 hours or on HIGH for 8-10 hours (can be done overnight).
2. Set oven to 400°F. Separate meat from fat and drippings, and place in a separate bowl. Stir in enough BBQ sauce to thoroughly moisten and flavor meat.
3. Roll burritos with BBQ pork, avocado, and cilantro, and place in a 9x13 inch glass baking dish.
4. Top with cheese and place in oven. Cook for 5-10 minutes or until heat through and cheese is melted. Garnish with sour cream and salsa.

Serves 6-8



This recipe is ideal for using the Auto Cook Mode. Refer to pg. 7 for instructions.

E46



This recipe is ideal for using the Dual Cycle Mode. Refer to pg. 10 for instructions.

## Sweet and Spicy Pork Picadillo

2 pound boneless pork country-style ribs, trimmed of excess fat and cut into 1-inch cubes\*  
2 tablespoons olive oil  
2 yellow onions, cut into 1/4-inch dices  
4 cloves of garlic, minced  
2 15-ounce can diced tomatoes, undrained  
6 tablespoons cider vinegar  
4 chipotle peppers (canned, in Adobo sauce), chopped\*\*  
1 cup raisins, chopped  
1 teaspoon cumin  
1 teaspoon cinnamon  
Salt and freshly ground pepper  
Prepared white rice

\*Other cuts of boneless pork can also be used, such as trimmed pork shoulder.

\*\*If using dried chipotles, soak in warm water to soften before chopping - about 20 minutes.

1. Heat olive oil in sauté pan, add onions and garlic, and sauté over medium-low heat until softened, about 4 minutes.
2. Add pork and brown. Transfer to stoneware.
3. In a separate bowl, combine tomatoes, cider vinegar, chipotle peppers, raisins, cumin, and cinnamon. Blend well and pour over pork.
4. Cover; cook on LOW for 6-8 hours or on HIGH for 3-5 hours or until pork is very tender. Using the tines of two forks, shred the pork. Put the lid back on the stoneware and cook for 1/2 hour more on HIGH.
5. Season with salt and pepper and serve over rice.

Serves 8



This recipe is ideal for using the Auto Cook Mode. Refer to pg. 7 for instructions.

E47



This recipe is ideal for using the Dual Cycle Mode. Refer to pg. 10 for instructions.



## Sweet and Spicy Pork Picadillo

2 pound boneless pork country-style ribs, trimmed of excess fat and cut into 1-inch cubes\*  
2 tablespoons olive oil  
2 yellow onions, cut into 1/4-inch dices  
4 cloves of garlic, minced  
2 15-ounce can diced tomatoes, undrained  
6 tablespoons cider vinegar  
4 chipotle peppers (canned, in Adobo sauce), chopped\*\*  
1 cup raisins, chopped  
1 teaspoon cumin  
1 teaspoon cinnamon  
Salt and freshly ground pepper  
Prepared white rice

\*Other cuts of boneless pork can also be used, such as trimmed pork shoulder.

\*\*If using dried chipotles, soak in warm water to soften before chopping - about 20 minutes.

1. Heat olive oil in sauté pan, add onions and garlic, and sauté over medium-low heat until softened, about 4 minutes.
2. Add pork and brown. Transfer to stoneware.
3. In a separate bowl, combine tomatoes, cider vinegar, chipotle peppers, raisins, cumin, and cinnamon. Blend well and pour over pork.
4. Cover; cook on LOW for 6-8 hours or on HIGH for 3-5 hours or until pork is very tender. Using the tines of two forks, shred the pork. Put the lid back on the stoneware and cook for 1/2 hour more on HIGH.
5. Season with salt and pepper and serve over rice.

Serves 8



This recipe is ideal for using the Auto Cook Mode. Refer to pg. 7 for instructions.

E47



This recipe is ideal for using the Dual Cycle Mode. Refer to pg. 10 for instructions.

## *Pork Tenderloin with Figs, Apricots, and Shitake Mushrooms*



*3 pounds pork tenderloin, rinsed, dried, and trimmed of excess fat or silver skin*  
*2 tablespoons olive oil*  
*3 large Vidalia onions, sliced into 1/4-inch slices*  
*2 cups sliced shitake mushrooms (4 or 5 stemmed mushrooms)*  
*20 dried figs*  
*1 cup dried apricots, chopped*  
*3 tablespoons balsamic vinegar*  
*1/2 cup chicken stock*  
*2 tablespoons chopped fresh sage*  
*Salt and freshly ground pepper*

1. Heat olive oil in sauté pan. Season pork tenderloin with salt and pepper, sear all sides in sauté pan, and remove from heat.
2. Layer onions in bottom of stoneware, place tenderloin on top, and add mushrooms, figs, and apricots.
3. In a separate bowl, combine balsamic, stock, and sage; pour over other ingredients.
4. Cover; cook on LOW for 6-8 hours or on HIGH for 3-5 hours, tossing ingredients several times to ensure even cooking, until meat is tender and onions have softened
5. Remove tenderloin, let rest for 5 minutes. Adjust seasoning to taste and cut into 3/4-inch slices. To serve top pork with the figs, apricots and mushrooms and broth.

Serves 4-6



This recipe is ideal for using the Auto Cook Mode. Refer to pg. 7 for instructions.

E48



This recipe is ideal for using the Dual Cycle Mode. Refer to pg. 10 for instructions.

## Smothered Autumn Pork Roast



*2 boneless pork loins, about 2-3 pounds each*  
*4 apples, peeled, cored and sliced*  
*2 large onions, peeled and sliced*  
*Salt and freshly ground pepper to taste*

1. Season the pork loins well with salt and freshly ground pepper.
2. Place pork in bottom of stoneware and place apples and onions on top.
3. Cover; cook on LOW for 10-12 hours or on HIGH for 6-8 hours, until meat pulls apart easily. Transfer pork to cutting surface and let rest for 10 minutes before slicing into  $\frac{1}{2}$ - $\frac{3}{4}$  inch pieces.
4. Top pork slices with apples and onions.

Serves 10-12



This recipe is ideal for using the Auto Cook Mode. Refer to pg. 7 for instructions.

E49



This recipe is ideal for using the Dual Cycle Mode. Refer to pg. 10 for instructions.

## Boneless Pork Roast with Garlic and Rosemary



2 boneless pork loins, about 2 pounds each, rinsed and patted dry  
6 tablespoons olive oil  
8 cloves of garlic, minced  
1 bunch chopped fresh rosemary  
1 lemon, cut into  $\frac{1}{8}$ - $\frac{1}{4}$  inch slices  
 $\frac{1}{4}$  cup white wine  
 $\frac{1}{2}$  cup chicken stock  
Kosher salt and pepper  
Butcher's twine

1. Place pork loins on your work surface and heavily season with salt and freshly ground pepper.
2. In a separate bowl, combine 2 tablespoons of olive oil, the garlic and the rosemary. Rub this all over the pork.
3. Roll and tie the pork snugly using butcher's twine. Tuck the slices of the lemon under the twine and into the ends of the roast.
4. Heat the remaining 1 tablespoon of olive oil in a sauté pan over medium heat. Sear the pork loins on all sides until just brown. Transfer to the stoneware.
5. Return the sauté pan to the heat and deglaze the pan with the white wine and the stock, using a wooden spoon to remove any caramelized bits. Pour over the pork.
6. Cover; cook on LOW for 8-10 hours or on HIGH for 5-7 hours. Remove from stoneware; allow roast to rest for 10 minutes before removing twine and slicing.
7. Adjust the seasoning to taste and pour juices over the sliced pork.

Serves 8-10



This recipe is ideal for using the Auto Cook Mode. Refer to pg. 7 for instructions.

E50



This recipe is ideal for using the Dual Cycle Mode. Refer to pg. 10 for instructions.

## Country-Style Pork Ribs



3 pounds boneless country-style pork ribs, rinsed and patted dry  
6 firm, crisp apples (such as Granny Smith, Macouns, Galas, Braeburns),  
peeled, cored and cut into 1/4-inch slices  
6 leeks, trimmed of roots and green tops, sliced (across into 1/4-inch slices)  
and rinsed to remove any grit (about 6 cups)  
1/4 cup white wine  
1/4 cup chicken stock  
4 cloves of garlic, smashed  
2 tablespoons chopped fresh sage  
Salt and pepper

1. Trim pork of any excess fat. Season well with salt and pepper, and transfer to the stoneware.
2. Put leeks and apples on top of pork. In a separate bowl, add wine, stock, garlic, sage, salt, and pepper. Blend and pour into stoneware.
3. Cover; cook on LOW for 7-9 hours or on HIGH for 5-7 hours, until pork is tender and apples and leeks have softened, turning once or twice to ensure even cooking. Adjust seasoning to taste.
4. Spoon leeks and apples onto a serving dish and top with pork.

Serves 4-6



This recipe is ideal for using the Auto Cook Mode. Refer to pg. 7 for instructions.

E51



This recipe is ideal for using the Dual Cycle Mode. Refer to pg. 10 for instructions.

## Baby Back Ribs

---

2 tablespoons ground cumin  
2 tablespoons chili powder  
2 tablespoons brown sugar  
4 teaspoons ground coriander  
1/2 teaspoon ground cinnamon  
2 teaspoon salt  
1 teaspoon ground black pepper  
4-6 pounds baby back pork ribs  
2/3 cup bourbon  
1/2 cup brown sugar, packed  
1/2 cup chili sauce

1. In a small bowl, combine the cumin, chili powder, 2 tablespoon of sugar, coriander, cinnamon, salt, and pepper. Stir to thoroughly combine, and rub all over the ribs.
2. Place the ribs into the stoneware. In a small bowl, stir together the bourbon, 1/2 cup sugar, and chili sauce and pour all over the ribs.
3. Cover; cook on LOW for 8-10 hours or on HIGH for 4-6 hours. Occasionally brush sauce onto the ribs.

Serves 8

## Beer-Braised Kielbasa

---

5 packages kielbasa, cut into 1/2-inch slices  
1 can beer  
2 cups brown sugar

1. Place kielbasa into stoneware.
2. Combine beer and brown sugar and pour over kielbasa.
3. Cover; cook on LOW for 7-8 hours or on HIGH for 4-5 hours, stirring occasionally.

Serves 12-15



This recipe is ideal for using the Auto Cook Mode. Refer to pg. 7 for instructions.

E52



This recipe is ideal for using the Dual Cycle Mode. Refer to pg. 10 for instructions.

## Sausage and Pepper Submarine Sandwiches

6 red bell peppers, sliced thin  
4 yellow onions, sliced thin  
 $\frac{1}{4}$ - $\frac{1}{2}$  cup extra virgin olive oil, divided  
1 tablespoon dried oregano  
2 teaspoons dried parsley flakes  
2 teaspoon salt  
1 teaspoon ground black pepper  
2 teaspoon red pepper flakes (optional)  
4 pounds hot or sweet Italian sausage  
Submarine rolls

1. Place the sliced peppers and onions in the stoneware. Drizzle with 2 tablespoon of oil and add the seasonings. Stir to thoroughly combine.
2. In a skillet over medium-high heat, add  $\frac{1}{2}$  the remaining oil and brown the sausage in two batches, adding more olive oil if necessary.
3. Place sausage over the vegetables in the stoneware, cover, and cook on LOW for 4-6 hours or on HIGH for 2-4 hours. Remove sausage to a submarine roll and cover with the peppers and onions. Repeat with remaining sausages and vegetables.

Serves 10-12



This recipe is ideal for using the Auto Cook Mode. Refer to pg. 7 for instructions.

E53



This recipe is ideal for using the Dual Cycle Mode. Refer to pg. 10 for instructions.

## Beef:

# Maple Whiskey Glazed Beef Brisket



2 beef briskets, about 2-2½ pounds each, scored with a knife on both sides

¼ cup olive oil

1 cup real maple syrup

½ cup whiskey

¼ cup brown sugar

2 tablespoons tomato paste

2 oranges, zested and then juiced

4 cloves of garlic, smashed

8 thin slices fresh ginger (¼-inch thick)

2 teaspoons cayenne pepper

2 tablespoons coarse salt

1 teaspoon freshly ground black pepper

1. Combine cayenne pepper, salt, and ground black pepper. Rub all over brisket and place in a plastic zipper bag, bowl or other container.
2. Combine remaining ingredients in a separate bowl and blend to mix. Pour over brisket and marinate for 2 hours or overnight.
3. Transfer brisket and marinade to stoneware, cover, and cook on LOW for 9-12 hours or on HIGH for 4-6 hours, turning once or twice. Adjust seasoning to taste. Thinly slice across the grain and serve with liquid spooned over brisket.

Serves 8-10



This recipe is ideal for using the Auto Cook Mode. Refer to pg. 7 for instructions.

E54



This recipe is ideal for using the Dual Cycle Mode. Refer to pg. 10 for instructions.



## Carne Relleno



2 pieces of flank steak, about 2 pounds each, scored on one side  
2 4-ounce can whole green chilies (jalapeños)  
8 ounces cream cheese  
2 12-ounce jars prepared salsa verde  
String to tie roll

1. Divide cream cheese among the chilies, stuffing each chili.
2. Lay the chilies into the steak, unscored side. Roll the steak and tie with string.
3. Place into stoneware; pour the salsa verde over meat.
4. Cover; cook on LOW for 6-9 hours or 3-5 hours on HIGH.
5. Remove from stoneware, cut string and cut into 6 pieces. To serve, spoon sauce over meat.

Serves 10-12



This recipe is ideal for using the Auto Cook Mode. Refer to pg. 7 for instructions.

E55



This recipe is ideal for using the Dual Cycle Mode. Refer to pg. 10 for instructions.

## Hearty Beef Short Ribs



8 bone-in beef short ribs, about 6 pounds (or 8-12 boneless beef short ribs, about 4 pounds)  
2 tablespoons coarse salt  
2 tablespoons freshly ground black pepper  
2 tablespoons olive oil  
4 carrots, cut into 1/4-inch dices  
4 celery stalks, cut into 1/4-inch dices  
2 large yellow onion, cut into 1/4-inch dices  
6 cloves of garlic, minced  
2/3 cup red wine  
2/3 cup crushed tomatoes  
2/3 cup balsamic vinegar  
3 bay leaves

1. Season each short rib with coarse salt and freshly ground black pepper and coat with olive oil.
2. Heat 2 tablespoons olive oil in a large sauté pan. Sear short ribs until just browned, in batches if necessary, about 2-3 minutes per side. Transfer to stoneware.
3. Top meat with celery, carrots, onions, garlic, and bay leaves.
4. In a separate bowl, combine wine, crushed tomato, vinegar, salt, and pepper. Stir to blend. Pour into stoneware.
5. Cover; cook on LOW for 8-10 hours or on HIGH for 5 7 hours, turning once or twice, until meat is tender and easily falling from bone (or fork-tender if using boneless).
6. Remove ribs from stoneware. Using an immersion blender (or traditional blender), puree the sauce, leaving some chunkiness.
7. Pour sauce over ribs and serve.

Serves 6-8



This recipe is ideal for using the Auto Cook Mode. Refer to pg. 7 for instructions.

E56



This recipe is ideal for using the Dual Cycle Mode. Refer to pg. 10 for instructions.

## Beef Ale Stew with Caramelized Onions and Fennel



2 tablespoons unsalted butter  
2 teaspoons dried Italian seasoning  
1 teaspoon dried tarragon  
1 pound thin-sliced yellow onion  
2 cups fresh chopped fennel  
2 pounds beef top round steak, sliced thin  
1 pound white button mushrooms, halved  
1 14-ounce can beef broth  
1 14.5-ounce can diced roasted garlic tomatoes, undrained  
1 teaspoon paprika  
1 12-ounce bottle amber ale beer  
1 tablespoon dark brown sugar  
2 teaspoons beef & pork seasoning or rub  
1 bay leaf  
6 cups prepared white rice  
 $\frac{1}{4}$  cup fresh chopped Italian parsley

1. Place butter in stoneware and set to HIGH until butter melts. Add Italian seasoning, tarragon, onions, and fennel. Cover and cook on HIGH for 15 to 20 minutes, until caramelized.
2. Add the beef slices, mushrooms, beef broth, tomatoes, paprika, amber ale beer, brown sugar, seasoning or rub, and bay leaf. Cover; cook on HIGH for 1 hour and then on LOW for 5 to 6 hours.
3. Remove bay leaf. On a large platter, make a ring of white rice and fill the center with beef stew. Top with fresh chopped Italian parsley.

Serves 6-8



This recipe is ideal for using the Auto Cook Mode. Refer to pg. 7 for instructions.

E57



This recipe is ideal for using the Dual Cycle Mode. Refer to pg. 10 for instructions.

## Winter Comfort Pot Roast



2 carrots, peeled and halved  
1 medium onion, peeled, roots removed, and cut into 4 wedges  
4 cloves garlic, peeled and minced  
2 tablespoons fresh thyme  
1 bay leaf  
3 whole cloves  
1 cup chicken broth  
1 cup dry white wine  
3 tablespoons tomato paste  
2 tablespoons extra-virgin olive oil  
1/4 pound pancetta, thickly sliced, diced  
1 4-pound boneless beef chuck pot roast  
Salt and pepper  
2 tablespoons brandy  
1/2 teaspoon prepared horseradish  
1/2 teaspoon Dijon mustard  
2 tablespoons sour cream  
1 teaspoon flour  
2 tablespoons Italian flat-leaf parsley, minced

1. Place the carrots, onion, garlic, herbs, and cloves into the stoneware.
2. Combine broth, wine, and tomato paste in a separate bowl; set aside.
3. Add olive oil and pancetta to a large, heavy skillet set to medium-high heat and cook pancetta until lightly browned. Remove pancetta and add to stoneware.
4. Pat roast dry with paper towels and season generously with salt and pepper. Sear on all sides in skillet set to medium-high heat, about 4 minutes per side.
5. Remove roast and place in stoneware over vegetables. In skillet set to medium heat, deglaze the pan with the broth mixture, scraping up all browned bits of pancetta and pot roast stuck to pan.

Recipe continued on next page.



This recipe is ideal for using the Auto Cook Mode. Refer to pg. 7 for instructions.

E58



This recipe is ideal for using the Dual Cycle Mode. Refer to pg. 10 for instructions.

## Winter Comfort Pot Roast (cont.)



6. Pour the liquid over the roast, cover, and cook on LOW for 8-10 hours or on HIGH for 5-7 hours.
7. Remove roast, carrots and onions and strain and reserve liquids. Using a skimmer or defatter, remove and discard fat from liquid. Place in saucepan, and boil and reduce liquids by half, about 10 minutes. Stir in the brandy, horseradish and mustard.
8. In a small bowl, stir together the sour cream and the flour. Stir in 2 tablespoons of the brandy sauce to the sour cream and flour mixture and add back to the pan. Cook gently over medium heat for about 4-5 minutes.
9. Slice thinly, and serve with sauce and parsley to garnish.

Serves 6-8

## Simple Korean Flank Steak



*6 pounds flank steak*  
*1 cup soy sauce*  
*1/2 cup brown sugar*  
*2-4 tablespoons freshly grated gingerroot*  
*6 cloves garlic, minced*  
*1 bunch scallions, minced*

1. In a bowl, mix soy sauce, brown sugar, gingerroot, garlic, and scallions.
2. With a fork, prick the surface of the steak and place in marinade for 2 hours or overnight.
3. Put steak and marinade into the stoneware, cover, and cook on LOW for 8-10 hours or on HIGH for 5-7 hours.

Serves 8-10



This recipe is ideal for using the Auto Cook Mode. Refer to pg. 7 for instructions.

E59



This recipe is ideal for using the Dual Cycle Mode. Refer to pg. 10 for instructions.

## Six Pepper Chili



- 3 pounds hamburger
- 1 12-ounce can beef broth
- 1 teaspoon oregano
- 3 teaspoons chili powder
- 1 teaspoon cumin
- 5 cloves garlic
- 2 12-ounce cans pinto beans, drained and rinsed
- 2 12-ounce cans of red kidney beans, drained and rinsed
- 5 dashes hot sauce
- 2 28-ounce cans crushed Italian tomatoes
- 1 12-ounce can of tomato paste
- 1 teaspoon salt
- 1 teaspoon black pepper
- 1 teaspoon cayenne pepper
- 1 red pepper, seeded and diced
- 1 green pepper, seeded and diced
- 2 Serrano chili peppers, minced
- 1 long red pepper, diced

1. In a large skillet, brown meat.
2. Add meat and other ingredients to stoneware.
3. Cover and cook on LOW for 6-8 hours or on HIGH for 5-7 hours, stirring occasionally.
4. Mix well before serving.

Serves 6-8



This recipe is ideal for using the Auto Cook Mode. Refer to pg. 7 for instructions.

E60



This recipe is ideal for using the Dual Cycle Mode. Refer to pg. 10 for instructions.

## Beef, Bacon, and Mushroom Stew



3-4 pounds beef chuck, cut into 1-inch pieces  
1 onion, chopped  
2 carrots, chopped coarsely  
6 cloves garlic, chopped coarsely  
4 bay leaves  
4 sprigs fresh thyme  
10 black peppercorns  
2 tablespoons olive or vegetable oil  
½ pounds bacon or pancetta, diced  
2 onions, chopped  
2 carrots, diced  
¼ cup flour  
2 cups red wine  
2 cups beef broth  
1 tablespoon tomato paste  
1 pound mushrooms  
2 cloves fresh garlic, coarsely chopped  
Salt and pepper  
Freshly chopped Italian flat-leaf parsley

1. Combine first seven ingredients in a bowl. Place in refrigerator to marinate for 12 hours. Remove meat from marinade, pat meat dry, and discard marinade.
2. In a large heavy skillet, pour 1 tablespoon of oil and set to medium heat. Add bacon and cook until it just starts to brown. Remove bacon, reserving bacon fat, and place bacon in the stoneware.
3. Salt and pepper the beef, and brown the meat, in batches if necessary, until browned on all sides. Place meat in the stoneware.
4. Briefly sauté onions, carrots and mushrooms in reserved bacon fat until lightly browned.

Recipe continued on next page.



This recipe is ideal for using the Auto Cook Mode. Refer to pg. 7 for instructions.

E61



This recipe is ideal for using the Dual Cycle Mode. Refer to pg. 10 for instructions.

## Beef, Bacon, and Mushroom Stew (cont.)



5. Add flour and sauté for 5 minutes on medium heat. Add vegetables to the stoneware.
6. Stir in red wine, beef broth, and tomato paste. Cover; cook on LOW for 5-7 hours or on HIGH for 4-6 hours.
7. Cool and place in refrigerator overnight.
8. Set oven to 300°F. Skim fat off top of dish and add fresh garlic and salt and pepper to taste.
9. Place stoneware in the oven and cook until dish begins to simmer. Stir and simmer for 5 minutes.
10. Garnish with parsley.

Serves 8



This recipe is ideal for using the Auto Cook Mode. Refer to pg. 7 for instructions.

E62



This recipe is ideal for using the Dual Cycle Mode. Refer to pg. 10 for instructions.



## Vegetarian:

# Chunky Vegetarian Chili



- 1 tablespoon olive oil
  - 1½ cups Vidalia onion, chopped (or other large, sweet yellow onion)
  - 3 cloves garlic, minced
  - ¾ cup red bell pepper, chopped
  - ½ cup green bell pepper, chopped
  - 1 cups celery, chopped
  - 1 28-ounce can whole tomatoes, undrained and chopped
  - 1 16-ounce can stewed tomatoes, undrained
  - 1 15-ounce can diced tomatoes, drained
  - 1 15-ounce cans black beans, rinsed and drained
  - 1 15-ounce can pinto beans, rinsed and drained
  - 1½ tablespoons chili powder
  - 1 teaspoon ground cumin
  - 1 teaspoon dried oregano
  - 1 bay leaf
  - ½ teaspoon salt
  - ½ teaspoon black pepper
  - 1 cup zucchini, chopped chunky
  - 1 cup mushrooms, chopped chunky
  - 1 package frozen corn kernels
  - ¼ cup sour cream for garnish (optional)
  - ¼ cup shredded Cheddar cheese for garnish (optional)
- Prepared rice

1. Heat the oil in a Dutch oven or large sauté pan over medium heat.
2. Add onion, garlic, bell peppers, and celery.
3. Sauté 5 minutes or until tender and transfer to stoneware.
4. Add remaining ingredients, cover, and cook on LOW for 6-8 hours or on HIGH for 5-7 hours.
5. Serve over white or brown rice and garnish with a dollop of sour cream and/or sprinkled with shredded cheese.

Serves 6-8



This recipe is ideal for using the Auto Cook Mode. Refer to pg. 7 for instructions.

E63



This recipe is ideal for using the Dual Cycle Mode. Refer to pg. 10 for instructions.

## Mushroom Barley Stew



- 1/4 pound of pearl barley, rinsed and checked over*
- 1 10-ounce package of fresh mushrooms, such as Crimini, rinsed and thinly sliced*
- 1 cup dried mushrooms, Porcini if possible, soaked to cover in warm water to soften, liquid reserved*
- 2 carrots, peeled and cut into 1/4-inch dices*
- 2 celery stalks, cut into 1/4-inch dices*
- 1 yellow onion, cut into 1/4-inch dices*
- 8-10 cups chicken (or mushroom) stock*
- 1 tablespoon fresh thyme*
- 2 bay leaves*
- 1 tablespoon tomato paste*
- Salt and pepper*
- 2 tablespoons Italian flat-leaf parsley*

1. Add all ingredients, starting with 8 cups of stock and including reserved liquid from dried mushrooms (be careful to discard any sediment) to stoneware. Stir to blend.
2. Cover; cook on LOW for 5-6 hours or on HIGH for 3-5 hours, until barley and vegetables have softened. If more liquid is needed, add more stock (this will require more cooking time after adding).
3. Adjust seasoning and serve with a sprinkling of parsley.

Serves 8-10



This recipe is ideal for using the Auto Cook Mode. Refer to pg. 7 for instructions.

E64



This recipe is ideal for using the Dual Cycle Mode. Refer to pg. 10 for instructions.

## Easy Pizza or Pasta Sauce

---

2 whole bulbs garlic, peeled and coarsely chopped  
3 tablespoons olive oil  
3 28-ounce cans peeled plum (Roma) tomatoes  
2-3 tablespoons sugar  
Salt and pepper  
2 bunches fresh basil, cut into ribbons or torn

1. In a frying pan set to medium heat, heat olive oil. Add garlic to the pan and cook until fragrant and softened, stirring constantly and being careful not to burn, about 2 minutes. Remove from heat, and add garlic and oil to stoneware.
2. Add tomatoes, sugar, and salt and pepper to taste. Cover; cook on LOW for 6-7 hours or on HIGH for 3-4 hours.
3. Stir in basil; toss with pasta or spread on pizza round as desired and pass the cheese.

Serves 8-10



This recipe is ideal for using the Auto Cook Mode. Refer to pg. 7 for instructions.

E65



This recipe is ideal for using the Dual Cycle Mode. Refer to pg. 10 for instructions.

## Soups and Chowders

### *Black Bean Chipotle Soup \**



1 pound dry black beans, rinsed, drained and checked for foreign objects  
2 stalks celery, cut into 1/4-inch dices  
2 carrots, peeled and cut into 1/4-inch dices  
1 yellow onion, peeled and cut into 1/4-inch dices  
2 chipotle peppers (canned in adobo sauce), chopped\*\*  
1 cup crushed tomatoes  
1 4-ounce can chopped green chilies, drained (hot or mild, depending on preference)  
6 cups chicken (or vegetable) stock  
2 teaspoons cumin  
Salt and pepper

### Toppings

Sour cream

Salsa

Fresh cilantro, chopped

*\*For an even heartier soup, add 1 cup of diced, cooked spicy sausage, such as andouille, chorizo, or linguica. Add to soup after soup has been pureed and cook for 30 minutes more.*

*\*\*If using dried chipotle peppers, soak in warm water to soften before chopping about 20 minutes.*

1. Place beans in a medium pan, cover with cool water, bring to a boil, boil for 2 minutes, remove from heat, and let stand for 1 hour and rinse. Add to stoneware and top with celery, carrots, and onions.
2. In a separate bowl, combine chipotles, crushed tomatoes, green chilies, stock, cumin, and salt and pepper to taste. Mix to blend and pour into stoneware.

Recipe continued on next page.



This recipe is ideal for using the Auto Cook Mode. Refer to pg. 7 for instructions.

E66



This recipe is ideal for using the Dual Cycle Mode. Refer to pg. 10 for instructions.

## Black Bean Chipotle Soup (cont.)



3. Cover; cook on HIGH for 1 hour and then on LOW for 6 hours, until beans are tender to bite. Adjust seasoning to taste.
4. Puree with an immersion blender (or traditional blender) to a slightly chunky consistency. If using, add additional sausage and cook for 30 minutes more.
5. Serve topped with a dollop of sour cream, spoon of salsa and sprinkling of chopped cilantro.

Serves 4-6

## Curried Butternut Squash Soup

*2 pounds butternut squash, rinsed, peeled, seeded, and chopped into 1-inch cubes*  
*1 firm, crisp apple (such as Macoun, Gala, Braeburn), peeled, seeded, and chopped*  
*1 yellow onion, chopped*  
*4-5 cups chicken stock*  
*1 tablespoon curry powder*  
*1/4 teaspoon ground cloves*  
*Salt and pepper*  
*1/4 cup chopped dried cranberries*

1. Add squash, apple, and onion to the stoneware.
2. In a separate bowl, combine 4 cups stock, curry, and cloves and mix. Pour over squash and apples.
3. Cover; cook on LOW for 5-5 1/4 hours or on HIGH for 3 1/4-4 hours, until ingredients have fully softened.
4. Puree with an immersion blender (or traditional blender). Adjust salt and pepper to taste and add more stock if soup is too thick (this will require more cooking time after adding).
5. Serve in bowls, garnishing with sprinkle of dried cranberries.

Serves 6-8



This recipe is ideal for using the Auto Cook Mode. Refer to pg. 7 for instructions.

E67



This recipe is ideal for using the Dual Cycle Mode. Refer to pg. 10 for instructions.

## Chicken Tortilla Soup

- 8 boneless, skinless chicken thighs, rinsed, dried, and seasoned with salt and pepper
- 2 4-ounce can chopped green chilies, drained (hot or mild, depending on preference)
- 4 cloves garlic, minced
- 2 yellow onions, diced
- 2 28-ounce cans of diced tomatoes, undrained
- 4 - 5 cups chicken broth
- 2 teaspoons cumin
- Salt and pepper

### Toppings

- 8 corn tortillas, sliced into 1/4-inch strips
- 1/4 cup chopped cilantro
- 1 cup shredded Monterey Jack cheese
- 2 avocados, diced and tossed with lime juice to prevent browning
- 2 limes

1. Place chicken in stoneware.
2. In a separate bowl, combine chilies, garlic, onion, tomatoes, 3 cups chicken broth and cumin. Blend and pour over chicken.
3. Cook on LOW for 7-9 hours or on HIGH for 3-5 hours. When chicken is very tender, use the tines of two forks to shred the chicken. Adjust seasoning, and add additional chicken broth if soup is too thick, noting that the soup will also be thickened with the addition of the sliced tortillas.
4. Just before serving, add sliced tortillas and chopped cilantro to stoneware. Stir to incorporate and to soften tortillas. Adjust seasoning to taste.
5. Serve in soup bowls, topping each with shredded cheese, diced avocado, and a squeeze of lime.

Serves 8-10



This recipe is ideal for using the Auto Cook Mode. Refer to pg. 7 for instructions.

E68



This recipe is ideal for using the Dual Cycle Mode. Refer to pg. 10 for instructions.

## Beggar's Chowder

*¼ cup unsalted butter at room temperature*  
*¼ cup all-purpose flour*  
*1 tablespoon garlic salt*  
*1 tablespoon thyme*  
*1 tablespoon sweet Hungarian paprika*  
*½ teaspoon coarsely ground black pepper*  
*4 skinless, bone-in turkey thighs, trimmed of visible fat*  
*Non-stick cooking spray*  
*2 14.75-ounce cans cream style sweet corn*  
*1 10.5-ounce can condensed chicken broth, undiluted*  
*1 cup diced red bell pepper*  
*1 cup diced green bell pepper*  
*1½ cups diced yellow onion*  
*1 pound cleaned, stemmed white mushrooms, halved or quartered if large*  
*1 14.5-ounce can petite diced tomatoes, drained*  
*1½ cups heavy whipping cream*  
*½ cup cilantro or parsley*  
*Salt and pepper*

1. Combine butter, flour, garlic salt, pepper, thyme, and paprika in small (1-quart) mixing bowl. Using the back of a wooden spoon, work the mixture to form a smooth paste. Rub the paste into all sides of the turkey thighs
2. Spray the stoneware with non-stick cooking spray. Place the turkey thighs in the bottom of the stoneware and cover with red and green peppers, onion, corn, and chicken broth.
3. Cover; cook on HIGH for 3 hours or until turkey is fork tender. Remove turkey thighs from stoneware and set aside until cool enough to handle.
4. While turkey cools, add mushrooms and tomatoes to liquid in stoneware. Cover and continue to cook on HIGH for ½ hour more.
5. While mushrooms are cooking, remove the turkey meat from the bones in bite size pieces. When mushrooms are tender, return the turkey to the chowder. Add the heavy cream and cilantro or parsley and cook, covered, until heated through, about 15 minutes more. Taste for seasoning, adding salt and pepper to taste.

Serves 8



This recipe is ideal for using the Auto Cook Mode. Refer to pg. 7 for instructions.

E69



This recipe is ideal for using the Dual Cycle Mode. Refer to pg. 10 for instructions.

## *Shrimp Thai Soup with Lime and Chilies*

*3/4 pound uncooked large shrimp, peeled and deveined, shells reserved*  
*2 1/2 quarts low salt chicken broth*  
*1 cup diced carrots*  
*3 stalks lemongrass, thinly sliced*  
*2 inches gingerroot, peeled and grated*  
*2 tablespoons garlic, minced*  
*1 1/2 tablespoons fresh Thai basil (or basil)*  
*1 1/2 tablespoons fresh mint*  
*1 1/2 tablespoons finely chopped cilantro*  
*1 serrano chili, stemmed, thinly sliced*  
*1 1/2 teaspoon fresh lime juice*  
*6 thin lime slices*

1. Halve shrimp lengthwise. Place in refrigerator.
2. Add shrimp shells, broth, carrot, lemongrass, gingerroot, and garlic into stoneware. Cover; cook on LOW for 3 1/2-4 1/2 hours or on HIGH for 2-3 hours.
3. Strain and reserve broth, discard solids. Pour broth into stoneware.
4. Add shrimp, herbs, chili, and lime juices. Cover, and cook on HIGH until shrimp are cooked, about 15 minutes. Garnish with lime slices.

Serves 6



This recipe is ideal for using the Auto Cook Mode. Refer to pg. 7 for instructions.

E70



This recipe is ideal for using the Dual Cycle Mode. Refer to pg. 10 for instructions.



## *New England Clam Chowder*

---

*1 pound sliced bacon*  
*4 onions, chopped*  
*2 16-ounce containers of clams in juice*  
*4 large cloves garlic, minced*  
*12 new potatoes, cubed*  
*6 cups chicken broth, clam broth or fish fumet*  
*1 tablespoon salt*  
*2 teaspoons pepper*  
*1 stick butter*  
*8 tablespoons flour*  
*1 13-ounce cans evaporated milk*  
*1-2 cups heavy cream*

1. Sauté bacon and onion in a skillet.
2. Add bacon, onion, clams and juice, garlic, potatoes, broth, salt and pepper.
3. Cover; cook on LOW for 6-8 hours or on HIGH for 2-4 hours.
4. Melt butter in saucepan on stovetop set to medium heat. Add flour and cook for about 3-4 minutes, stirring constantly. Reduce heat and whisk in evaporated milk. With a ladle, scoop out broth from stoneware and stirring constantly, whisk thickened mixture until smooth. Continue adding broth until mixture is pourable. Pour back into stoneware and stir until chowder is smooth. Stir in heavy cream and heat through. Do not simmer.

Serves 8-10



This recipe is ideal for using the Auto Cook Mode. Refer to pg. 7 for instructions.

E71



This recipe is ideal for using the Dual Cycle Mode. Refer to pg. 10 for instructions.

## *Split Pea Soup*

---

2 16-ounce packages dried split peas  
2 pounds cooked ham, diced  
14 cups water  
2 onions, chopped  
4 carrots, chopped  
1½ teaspoon salt  
8 sprigs fresh thyme, stemmed  
1 teaspoon black pepper

1. Add all ingredients to stoneware.
2. Cover; cook on LOW for 10-12 hours or on HIGH for 5½- 7½ hours.

Serves 8-10

## **Holidays and Special Occasions**

### *Stuffed Artichokes*

---

1 lemon, sliced in quarters  
6-8 artichokes, washed, tops sliced off and stems trimmed  
2 cups bread crumbs  
2 cups grated Pecorino Romano cheese  
1 large bunch flat leaf parsley, chopped  
2 teaspoons salt  
1 teaspoon freshly ground pepper  
2 tablespoons extra virgin olive oil

1. Fill stoneware with lemon slices and about 1½ inches of water.
2. Combine bread crumbs, cheese, parsley, salt, and pepper in a bowl. Spread artichoke leaves and fill pockets generously with bread crumb mixture until you reach the soft leaves near the center.
3. Place artichokes in stoneware standing up. Drizzle olive oil on top of each artichoke. Cover, and cook on LOW for 3-5 hours or on HIGH for 1½-2 ½ hours. Check for doneness after 3 hours on LOW or 1 hour on HIGH. Cook until leaves are tender and pull away from heart easily.

Serves 4



This recipe is ideal for using the Auto Cook Mode. Refer to pg. 7 for instructions.

E72



This recipe is ideal for using the Dual Cycle Mode. Refer to pg. 10 for instructions.

# Duck with Port, Mushroom, and Tart Cherry Glaze



4 bone-in, skin-on duck legs, about 1½-2 pounds total, rinsed and patted dry  
1 tablespoon olive oil  
¼ cup dried Porcini mushrooms, soaked in warm water to cover until softened and roughly chopped, reserving liquid (or ¼ cup sliced fresh Shitakes)  
½ cup dried cherries  
4 cloves of garlic  
3 tablespoons apricot preserves  
¼ cup port wine  
1 shallot, thinly sliced  
16 sprigs fresh thyme, 8 whole, 8 chopped (about 1½ tablespoons)  
2 bay leaves  
Coarse salt and freshly ground pepper  
Butcher's twine

1. Season duck legs with coarse salt and freshly ground pepper.
2. Lay a duck leg on your work surface, skin side down and “open”.
3. Place 1 teaspoon of mushrooms, 3-4 dried cherries, 2 sprigs of thyme, and 1 clove of garlic on leg. Fold skin over filling and, using butcher's twine, firmly tie the duck leg closed. Repeat with each leg.
4. Heat olive oil in a sauté pan over medium heat. Sear duck legs until browned, 2-3 minutes per side. Transfer to stoneware.
5. In a separate bowl, combine remaining mushrooms, 2 tablespoons reserved mushroom liquid (avoiding sediment), remaining cherries, 3 tablespoons apricot preserves, port, shallot, chopped thyme, and bay leaves. Season and whisk to combine.
6. Pour port liquid over duck.
7. Cover; cook on LOW for 6 hours, turning once or twice.
8. Remove duck from stoneware. Remove twine from legs with kitchen shears (be careful to remove all of twine).
9. Pour port liquid over a sieve, reserving cherries, etc. Allow remaining liquid to settle and skim off fat. Add cherries, etc., back to skimmed liquid, adjust seasoning, and pour over duck legs.

Serves 4



This recipe is ideal for using the Auto Cook Mode. Refer to pg. 7 for instructions.

E73



This recipe is ideal for using the Dual Cycle Mode. Refer to pg. 10 for instructions.

## Home-Style Corn Bread

*Non-stick cooking spray*  
*1¼ cups all-purpose flour*  
*¾ cup yellow cornmeal*  
*¼ cup granulated sugar*  
*1 tablespoon plus 1 teaspoon baking powder*  
*1½ teaspoons salt*  
*¼ teaspoon ground black pepper*  
*¼-½ teaspoon cayenne pepper*  
*1 egg*  
*1 cup evaporated milk*  
*6 tablespoons melted butter*

1. In a medium mixing bowl, combine the flour, cornmeal, sugar, baking powder, and seasonings.
2. In a small bowl, mix the egg, milk, and butter. Pour the wet into the dry ingredients and stir until just incorporated. Do not over-stir.
3. Place the batter into well greased stoneware, cover, and cook on LOW for 4-4½ hours or HIGH for 1-2 hours, until a toothpick inserted in center comes out clean.

Serves 6-8



This recipe is ideal for using the Auto Cook Mode. Refer to pg. 7 for instructions.

E74



This recipe is ideal for using the Dual Cycle Mode. Refer to pg. 10 for instructions.

## *Corned Beef and Cabbage*

---

*12 new potatoes, quartered*  
*4 carrots, sliced*  
*4 pounds corned beef brisket*  
*2 onions, sliced*  
*3 bay leaves*  
*8 black peppercorns*  
*1 head cabbage, wedged*

1. Place potatoes and carrots in bottom of stoneware. Add brisket, onion, bay leaves and peppercorns.
2. Add enough water to cover.
3. Cover; cook on LOW for 8-10 hours or on HIGH for 4-5 hours.
4. Add cabbage halfway through cooking.

Serves 6-8



This recipe is ideal for using the Auto Cook Mode. Refer to pg. 7 for instructions.

E75



This recipe is ideal for using the Dual Cycle Mode. Refer to pg. 10 for instructions.

## Stuffing with Apples, Canadian Bacon, and Toasted Pecans

- 8 cups bread stuffing or unseasoned croutons (about 1-inch cubes)\*
- ½ pound Canadian bacon, cut into ¼-inch dices
- 1 cup pecans, toasted and roughly chopped
- ½ cup dried cherries (or dried cranberries)
- 2 cups whole mushrooms, chopped (about 1 cup when chopped)
- 4 stalks of celery, cut into ¼-inch dices
- 2 crisp apples (such as Granny Smith, Macoun, Gala, Braeburn), peeled, cored and cut into ½-inch dices
- 2 tablespoons olive oil
- 5 cups chicken stock
- 2 shallots, peeled and minced
- 2 cloves garlic, minced
- 1 tablespoon fresh sage, minced
- Salt and pepper

\*To make your own bread stuffing using fresh or day-old bread, dice the bread into 1-inch cubes and heat in a low oven (225°F) until dried, about 15-20 minutes.

1. Add bread stuffing, apple, cherries, pecans, and sage to stoneware. Toss to combine.
2. In a large sauté pan, heat olive oil over medium-low heat. Add celery, shallot, garlic, mushrooms, and bacon. Sauté until softened and lightly browned, about 4-5 minutes.
3. Deglaze the pan with the chicken stock, using a wooden spoon to lift any bits from the bottom of the pan.
4. Pour this mixture into the stoneware. Add salt and pepper to taste, and stir to blend.
5. Cover; cook on HIGH for 3-5 hours, stirring periodically, until bread softens and stuffing begins to bind.

Serves 10-12



This recipe is ideal for using the Auto Cook Mode. Refer to pg. 7 for instructions.

E76



This recipe is ideal for using the Dual Cycle Mode. Refer to pg. 10 for instructions.

## Citrus spark salmon steaks

*Non-stick cooking spray*

*4 6-ounce salmon steaks or fillets, rinsed and blotted dry*

*½ cup water*

*½ cup orange juice*

*1 jalapeño pepper, seeded and minced*

*1 2-inch piece fresh ginger root, grated*

*1 large lime, thinly sliced*

*1 large lemon, thinly sliced*

*1 tablespoon extra virgin olive oil*

*Sea salt and pepper*

*Sprigs of fresh cilantro and lemon wedges, to garnish*

1. Coat stoneware with non-stick cooking spray. Arrange the salmon tightly in the bottom, tucking end of fillets under themselves to even out thickness of the fish.
2. In a small saucepan, combine water, orange juice, jalapeño pepper, and ginger; heat to boil over medium-high heat. Pour evenly around fish.
3. Arrange sliced lime and lemon evenly over fish. Drizzle with olive oil. Salt and pepper to taste.
4. Cover; cook on HIGH until the salmon is opaque and firm to the touch (about 1½ to 2 hours).
5. Turn off heat, and carefully lift fish out of stoneware and place on serving platter. Garnish with cilantro sprigs and lemon wedges. Serve immediately.

Serves 4



This recipe is ideal for using the Auto Cook Mode. Refer to pg. 7 for instructions.

E77



This recipe is ideal for using the Dual Cycle Mode. Refer to pg. 10 for instructions.

## *Holiday Ham with Ginger and Bourbon*

- 1 fully cooked ham, 5-6 pounds, outer skin and fat removed and scored in a diamond pattern  $\frac{1}{4}$ -inch around top and sides
- 1 4-inch piece of fresh ginger root, peeled with a spoon, finely grated
- $\frac{1}{2}$  cup bourbon
- $\frac{1}{2}$  cup brown sugar, packed

1. Place ham in stoneware. Combine ginger, bourbon and brown sugar and pour over ham.
2. Cover; cook on LOW for 7-8 hours or on HIGH for 4-5 hours, basting often, or until internal temperature is over 160°F.

Serves 6-8

## *Turkey with Pecan-Cherry Stuffing*



- 1 fresh or frozen boneless turkey breast (about 3-4 pounds)
- 2 cups cooked rice
- $\frac{1}{3}$  cup chopped pecans
- $\frac{1}{3}$  cup dried cherries or cranberries
- 1 teaspoon poultry seasoning
- $\frac{1}{4}$  cup peach, apricot, or plum preserves
- 1 teaspoon Worcestershire sauce

1. Thaw turkey breast, if frozen. Remove and discard skin. Cut slices  $\frac{3}{4}$  of the way through turkey at 1-inch intervals
2. Stir together rice, pecans, cherries, and poultry seasoning in large bowl.
3. Stuff rice mixture between slices. If needed, skewer turkey lengthwise to hold together.
4. Place turkey in the stoneware. Cover; cook on LOW for 6-8 hours or on HIGH for 4 $\frac{1}{2}$ -6 $\frac{1}{2}$  hours.
5. Stir together preserves and Worcestershire sauce. Spoon over turkey.
6. Cover; let stand for 5 minutes. Remove and discard skewer, if used.

Serves 6-8



This recipe is ideal for using the Auto Cook Mode. Refer to pg. 7 for instructions.

E78



This recipe is ideal for using the Dual Cycle Mode. Refer to pg. 10 for instructions.



## Sweet Potato Casserole with Gingersnap Topping

---

8 large sweet potatoes

1 tablespoon salt

Butter, as needed to grease the stoneware

1½ cups gingersnaps, finely ground in food processor

½ cup brown sugar, packed

¼ cup butter, melted

Dash nutmeg

1. Bake or boil the sweet potatoes until tender, and mash well with 2 teaspoons of salt.
2. Grease the bottom and sides of the stoneware with butter and add the mashed potatoes.
3. Combine the remaining ingredients in a bowl and spread over the top. Cover; cook on LOW for 4-5 hours or on HIGH for 2-2½ hours.

Serves 8-10



This recipe is ideal for using the Auto Cook Mode. Refer to pg. 7 for instructions.

E79



This recipe is ideal for using the Dual Cycle Mode. Refer to pg. 10 for instructions.

## Lamb Stew with Sherry and Thyme



*1/2 cup flour, seasoned with salt and pepper*  
*3 pounds lamb stew meat, cubed to 1-inch and trimmed of fat*  
*1/2 cup olive oil*  
*2 tablespoons butter*  
*4 celery stalks, cut into 1/2-inch dices*  
*4 carrots, peeled and cut into 1/2-inch dices*  
*6-8 Yukon gold potatoes, cut into 1/2-inch dices (about 2 cups)*  
*6 cloves garlic, peeled and chopped*  
*1/4 cup fresh thyme*  
*1 1/2 cups stock*  
*3/4 cup sherry*  
*Salt and pepper*  
*2 tablespoons minced fresh parsley*

1. Place seasoned flour in a bowl. Dredge lamb in flour and shake off excess.
2. Heat olive oil and butter in a large sauté pan. Add lamb and sauté until just browned, about 4 minutes. Transfer to stoneware and top with celery, carrots, potatoes, garlic, and thyme.
3. Place sauté pan back on heat and pour in the stock and 1/2 cup of sherry to deglaze the pan, using a wooden spoon to remove any caramelized bits from the pan. Pour into the stoneware.
4. Cover; cook on HIGH for 3-5 hours or on LOW 7-9 hours, until lamb is tender.
5. 1/2 hour before completion, add remaining sherry. Adjust seasonings, and serve with a sprinkling of parsley.

Serves 8



This recipe is ideal for using the Auto Cook Mode. Refer to pg. 7 for instructions.

E80



This recipe is ideal for using the Dual Cycle Mode. Refer to pg. 10 for instructions.

## Scalloped Potatoes and Ham



*Non-stick cooking spray*

*6 large russet potatoes scrubbed clean and sliced in 1/4-inch rounds*

*1 can cream of mushroom condensed soup*

*1 soup can water*

*1 ham steak, about 1 1/2 pounds, cubed*

*4 ounces shredded Cheddar cheese*

*Grill seasoning to taste*

1. Layer potatoes and ham in a slow cooker sprayed with nonstick spray.
2. Mix the soup, water, cheese, and seasoning together and pour mixture over ham and potatoes. Cover; cook on HIGH for 3 1/2 hours and then on LOW for 1 hour.

Serves 5



This recipe is ideal for using the Auto Cook Mode. Refer to pg. 7 for instructions.

E81



This recipe is ideal for using the Dual Cycle Mode. Refer to pg. 10 for instructions.

## Desserts

### *Crème Brûlée*

- 5 egg yolks
- 2 cups heavy cream
- 1 vanilla bean, split down the center
- ½ cup sugar
- ¼ cup raw sugar

1. Place 5<sup>2/3</sup>-cup ramekins or custard cups (2<sup>3/4</sup> inches wide by 1<sup>3/4</sup> inches high) inside stoneware. Pour water around ramekins so that water comes halfway up the sides of the ramekins. Remove ramekins and prepare custard.
2. Whisk the egg yolks briefly, set aside. Place the cream, vanilla bean and sugar in a small saucepan set over medium heat. Stir until mixture begins to boil. Remove from heat and let cool, allowing vanilla bean to steep in the cream. When cool, remove bean, scraping out the seeds into the mixture. Very slowly, pour into the egg yolks, whisking well. Strain the mixture through a fine sieve.
3. Pour the mixture into the ramekins and place in stoneware. Cover; cook on HIGH for 1-2 hours, or until custard is set but centers are still soft and jiggle. Carefully remove ramekins from stoneware, let cool, and refrigerate until ready to serve.
4. Spread tops of each custard generously with raw sugar and brûlée with a torch, gradually melting and browning the sugar in quick small, circles.

Serves 5



This recipe is ideal for using the Auto Cook Mode. Refer to pg. 7 for instructions.

E82



This recipe is ideal for using the Dual Cycle Mode. Refer to pg. 10 for instructions.

## Chocolate Hazelnut Polenta Cake

*Butter, as needed to grease the stoneware*

*4 ounces semi-sweet chocolate, melted*

*2 ounces semi-sweet chocolate, chopped into 1/4-inch pieces*

*4 tablespoons butter, melted*

*3/4 cup sugar*

*2 eggs*

*1/3 cup milk*

*1 teaspoon vanilla*

*3/4 cup cornmeal*

*1/4 cup flour*

*1 teaspoon baking powder*

*1/2 teaspoon baking soda*

*1 teaspoon cinnamon*

*1/2 teaspoon orange peel, finely minced*

*1/4 cup hazelnuts, finely chopped*

*Dash of salt*

1. Butter and flour bottom and 3 lowest side inches of stoneware, shaking out any excess flour.
2. In a small sauce pan, melt together 4 ounces of chocolate and butter. Transfer to mixing bowl.
3. Combine sugar, eggs, and vanilla; beat until fluffy. Add to chocolate and blend.
4. In a separate bowl, combine cornmeal, flour, baking powder, baking soda, cinnamon, orange peel, hazelnuts and salt. Mix to blend.
5. Add milk and cornmeal mixture alternately to chocolate until fully incorporated.
6. Fold in chocolate chunks.
7. Pour into stoneware, cover, and cook on HIGH for 2 1/2 hours, until cake sets but is still moist in the center.
8. Let cool and serve with ice cream or whipped cream.

Serves 6-8



This recipe is ideal for using the Auto Cook Mode. Refer to pg. 7 for instructions.

E83



This recipe is ideal for using the Dual Cycle Mode. Refer to pg. 10 for instructions.

## Apple Butter



*4 quarts peeled, thin-sliced McIntosh apples*  
*4 cups granulated white sugar*  
*1 teaspoon ground cinnamon*  
*¼ teaspoon ground cloves*  
*¼ teaspoon salt*

1. Stir all ingredients in stoneware. Cover; cook on HIGH for 1 hour and then on LOW for 7 hours, or until the apple butter is thick and brown. Stir occasionally throughout the day.
2. Apple butter will thicken as it cools. Spoon into sterilized pint jars and seal. If sealed, will keep for up to 1 year.



This recipe is ideal for using the Auto Cook Mode. Refer to pg. 7 for instructions.

E84



This recipe is ideal for using the Dual Cycle Mode. Refer to pg. 10 for instructions.

## Orange Soufflé

1 tablespoon butter to coat stoneware  
 $\frac{2}{3}$  cup superfine sugar plus extra sugar to coat stoneware and sprinkle on top of soufflé (regular sugar may be used if superfine is unavailable)  
1 orange, zest only  
6 tablespoons flour  
 $\frac{1}{2}$  cup milk  
8 egg yolks  
4 tablespoons unsalted butter, room temperature  
6 tablespoons orange liqueur  
1 tablespoons vanilla extract  
10 egg whites  
1 teaspoon salt  
4 tablespoons sugar  
Chocolate sauce or sweetened whipped cream (optional)

1. Rub the interior of stoneware with unsalted butter, and sprinkle with superfine sugar. Turn out and reserve any excess sugar.
2. Mix  $\frac{2}{3}$  cup sugar and orange zest in a food processor.
3. Whisk the flour and milk in a saucepan to blend. Beat in the orange scented sugar. Stir over medium heat until sauce thickens, then whisk as sauce comes to a boil. Continue whisking for 30 seconds and then remove from the heat. Let cool for a moment before beating in the egg yolks one at a time.
4. Add butter, orange liqueur and vanilla extract to the mixture and let stand at room temperature for 20 minutes to cool.
5. In a clean bowl, beat egg whites until foamy. Add salt and beat to soft peaks. Sprinkle in 4 tablespoons sugar and beat to stiff peaks.
6. Add in  $\frac{1}{4}$  of whipped egg whites to base and fold in. Fold in remaining whites and then scrape the mixture into the sugar-coated stoneware. Cover, cook on HIGH for 1 hour.
7. If desired, sprinkle the top of the soufflé with sugar and brûlée with a torch, gradually melting and browning the sugar in quick small, circles.
8. Spoon out and serve with chocolate sauce or sweetened whipped cream.

Serves 10



This recipe is ideal for using the Auto Cook Mode. Refer to pg. 7 for instructions.

E85



This recipe is ideal for using the Dual Cycle Mode. Refer to pg. 10 for instructions.

## *Cinnamon Ginger Poached Pears*

---

*6 cups water*  
*2 cups granulated sugar*  
*20 slices ginger*  
*4 cinnamon sticks*  
*12 pears, peeled and cored*  
*2 tablespoons candied ginger*

1. Combine all ingredients in stoneware. Cover; cook on LOW for 4-6 hours or on HIGH for 1½-2 hours.
2. Remove pears and cook uncovered for 30 minutes to let syrup thicken. Serve with ice cream or pound cake, spooning syrup over pears.

Serves 12



This recipe is ideal for using the Auto Cook Mode. Refer to pg. 7 for instructions.

E86



This recipe is ideal for using the Dual Cycle Mode. Refer to pg. 10 for instructions.



## *Notes*

---



**CROCK·POT**<sup>®</sup>  
◆ THE ORIGINAL SLOW COOKER ◆

**Smart-Set™**

© 2013 Sunbeam Products, Inc. doing business as Jarden Consumer Solutions. All rights reserved. Imported and distributed by Sunbeam Corporation (Canada) Limited, doing business as Jarden Consumer Solutions, 20B Hereford St., Brampton, Ontario L6Y 0M1.

SCVSM600B-CN\_13EFM1

Printed in China

9100050004077

GCDS-CRP30501-JC